



Nestlé PURINA

FERT: 12152506

BBE: 01/2015

GTIN CU: 4 x 7613033401091

Batch Code: 4023093107

GTIN DU: 1 x 07613033285837

BAKERS MEATY MEALS Small Dog Bf 4x1kg XB



(01)07613033285837(20)00(15)150100(10)4023093107

smaller chunks[®]
for SMALLER MOUTHS

Bar coding – getting it right

Recommendations for best practice by GS1 UK

1kg e



About GS1 UK

GS1 UK is a not-for-profit organisation owned by its members. We develop and implement global supply chain standards to make it faster, cheaper and safer for our members to serve their customers, regardless of where they are in the world.

The basis of our standards is the accurate identification of items such as products, assets, and even patients. We license globally unique numbers so that organisations can identify their items and develop global standards to help them share accurate data with their trading partners. We use our standards to develop solutions such as master data management, traceability and asset tracking, which can tackle real issues in the supply chain. GS1 standards are used over a billion times a day by millions of businesses globally.

GS1 UK was founded over 40 years ago and is one of 111 GS1 member organisations in over 150 countries worldwide.



Foreword



Bar coding has transformed value chain management over the last twenty years, and the ability to capture data automatically at every significant point in the chain enables faster and more efficient management. We are moving closer to the point when all the trading organisations in any value chain can begin to work together as one linked enterprise, with the scanning of products providing a flow of information that informs all other actions.



The accuracy of bar codes remains fundamentally important because when a bar code fails to scan it adds cost to the trading process. At best data has to be keyed in manually, and at worst customers may reject a complete consignment of goods, resulting in lost sales and possible financial penalties. It has been estimated that the cost of poor bar code quality in the UK is somewhere between £500 million and £1 billion pounds per year, and this booklet explains clearly how to achieve accurate bar codes that will scan the first time, every time.

Bar codes used in open trade must meet the requirements of the GS1 System which is managed globally by GS1. In the UK these GS1 standards are promoted and supported by GS1 UK.

Printing a good quality bar code that conforms to GS1 standards may cost more than printing unscannable symbols, but the benefits outweigh the costs. This booklet sets out recommendations for best practice that will require investment in appropriate staff and equipment.

This advice is provided by GS1 UK which is responsible for ensuring that UK users have the support they need in their use of the GS1 System. If the application of any of these guidelines is unclear, please contact the staff of GS1 UK for clarification. More detailed information about the technical aspects of the system can be obtained from GS1 UK and by consulting the GS1 General Specifications which are available to members at the website www.gs1uk.org.

JAMES E D SPITTLE
Chairman, GS1 UK

Contents

Foreword	1
1. What bar codes do	4
2. Number allocation	5
What happens when a consumer unit is also a traded unit?	
Number notification	
Re-using item numbers	
3. The ideal bar code	7
For consumer units	
For traded units	
For logistics units, for example pallets	
Bar code origination	
Bar code colours	
4. Choosing the correct bar code	12
5. Bar codes on consumer units	13
Main requirements	
X-dimension	
Quiet Zones	
6. Bar codes on traded units	15
Using EAN-13 or UPC-A bar codes	
Using ITF-14 bar codes	
Main requirements	
Bearer bars	
Quiet Zone indicators	
Using GS1-128 bar codes	
Main requirements	
Bearer bars	
Light margin indicators	
When are brackets required around the application identifiers?	
Products with a shelf life of up to 42 days	
Variable measure products	
7. Pallet labels	21
Position of label on pallet	
8. The verification process	24
9. Common problems to avoid	27
10. Checklist	31

11. Summary of best practice recommendations	32
12. Bar code management	34
13. Glossary of terms	35
Appendix 1	37
Bar code dimensions	
Appendix 2	38
GS1 Bar code specifications	
Appendix 3	39
Creating GTINs and SSCCs	
Global trade item numbers	
Creating GTIN-13s	
Creating GTIN-12s	
Creating branded variable measure restricted circulation numbers (RCNs)	
Creating own-label variable measure restricted circulation numbers (RCNs)	
Creating GTIN-14s	
Component parts of GTIN-14	
Creating SSCCs	
Check digit calculation	
Appendix 4	44
Printing techniques	
Printing on demand	
Appendix 5	46
Printing GS1-128 bar codes	
Function 1	
Choosing the correct character set	
Concatenation	
Choosing the correct size	
Height of bars	
Keeping adequate Quiet Zones	
When are brackets required around the application identifiers?	
Determining the length of a GS1-128 bar code	
Choosing the correct application identifiers	
Appendix 6	49
Symbol show through	
Appendix 7	50
How X-dimensions and magnification factors compare	
Further information	51

1. What bar codes do



All bar codes represent data in a machine readable form. The different widths of bars and spaces in a bar code symbol represent different numbers or letters which can be decoded by a scanner. The data is then sent back to the appropriate computer system where it is recorded and used to prompt further action.

Bar codes used at the retail point of sale represent a global trade item number (GTIN) which acts as a key to information held on a database. It is important that each GTIN correctly identifies the product and that the bar code representing this number can easily be seen and scanned successfully.



The bar codes used on outer cases (trade items that do not cross a retail point of sale) will sometimes represent a GTIN by itself. When it is also necessary to have additional information such as expiry dates, batch information or serial numbers in a machine readable form, this will also be included in the bar code.

Logistics labels are used to identify the units transported in the supply chain and examples include pallets of goods.

All of the bar codes in the GS1 System carry GS1 standard data. These standards are agreed internationally by GS1 members and are the basis for effective unambiguous communications between companies in value chains and their final customers.

This booklet will explain more about the printing and positioning of bar codes, but it is not intended as a replacement for the GS1 General Specifications. These specifications are available free of charge to GS1 UK members via the GS1 UK website at www.gs1uk.org.



2. Number allocation



It is vitally important that each company bar coding its products has a unique company prefix number from GS1 UK or another GS1 authority. This number is then used as the basis for the creation of unique global trade item numbers (GTINs) as explained in appendix 3.

Each company must ensure that every different product line has a different number. If particular levels of packaging also need to be identified for trading purposes, then each level being identified requires a different number.

The number allocated to a consumer unit (an item that could be sold at a retail point of sale) must be changed when

- the declared weight is different
- extra product is provided free, for example 10% extra
- the name of the product changes, for example from Marathon™ to Snickers™
- a price that is pre-printed on the packaging is changed

Numbers allocated to consumer units must remain unaltered when

- a promotional offer is being advertised
- the undeclared weight changes by an amount that does not affect its handling within any supply chain
- a minor packaging change, for example a different type of similar packaging material is now being used



Different numbers are required on outer cases (traded units or trade items that do not cross a retail point of sale) when

- they contain different quantities of the same consumer unit
- the products inside the outer case have a new item number
- a promotion needs to be distinguished for ordering and invoicing purposes
- the packaging of the consumer units changes significantly, for example when a glass container replaces a plastic container

Changes of number are required when the outer case needs to be distinguished from any other outer case. Changes in packaging material may affect the gross weight of the item even though all other aspects are unaltered. This weight change may affect the logistics processes involved in the product's handling, so a different number is required.

If the product is only ever sold at a traded unit level, either an EAN-13 bar code of at least 150% magnification, or an ITF-14 or GS1-128 bar code must be used.





What happens when a consumer unit is also a traded unit?

When a product is traded between companies and also sold at the retail point of sale, the product is both a traded unit and a consumer unit. Examples are a sack of potatoes, a toaster or a 12-pack of canned drinks. It does not need a new number for the second purpose as its identity is still the same.

Number notification

Poor communication of item numbers between trading partners prevents effective handling of trade information. Following good practice will achieve immediate improvements, at no extra cost.

- For proprietary branded products the manufacturer or supplier will notify the wholesalers or retailers of the GTINs being used
- For own brand products, the retailer or wholesaler will let the manufacturer know which numbers are to be used to identify new products

When a new product is being introduced, all the GTINs that relate to it must be notified to all the trading partners before the products are first supplied.



Re-using item numbers

The global trade item number (GTIN) for a product can be re-used if it is at least four years since the number was last used to identify something else. Even if the first product had a very short shelf life the number must not be re-used before this time has elapsed or it may cause confusion with your trading partners.

An exception is for clothing, when numbers can be re-used after 30 months. This is because many of these are used to identify fashion items that are only sold for one season.

Numbers used to identify items in healthcare must never be re-used.

A document fully explaining the GTIN allocation rules is available on the members' area on the GS1 UK website at www.gs1uk.org.

It is always worth checking whether re-using numbers will cause any problems with your major customers before doing this. In the music industry, for example, re-using numbers may cause problems because a re-issued recording may require the same number it had 10, 20 or 30 years ago.



3. The ideal bar code



The ideal bar code is one that represents the correct data, and is scannable on all correctly adjusted scanners. The GS1 General Specifications provide a basis for determining the correct size of a bar code and also recommend the use of verification equipment which can measure how well a bar code has been printed and give an indication of how easily it will be scanned in practice.

The correct type of bar code must be chosen before including it on the packaging of the product. The different types of product and the bar codes will now be explained.



The ideal bar code is one that represents the correct data, is printed within the allowable range of sizes and scans first time.

For consumer units

Scanners at the retail point of sale are designed to read EAN-13, UPC-A, EAN-8 and UPC-E bar codes so one of these symbols must be used. Most UK users will use EAN-13 bar codes on their products (or EAN-8 bar codes for very small products).

- Bar codes must be in the same location on all similar shaped products
- The bar code must be no closer than 8 mm to a seam or packaging fold
- The bar code must be on a flat or consistently curved surface
- The bar codes on consumer units must not be visible through the outer packaging
- For small cylindrical products, the bar code must be positioned vertically (ladder orientation), subject to the printing process and/or the direction of print

EAN-13

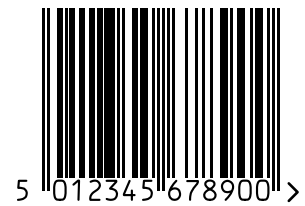

UPC-A



EAN-8



UPC-E



All of these bar codes are at 100% magnification.



For traded units

Scanners in warehousing and distribution and at the wholesale point of sale are designed to read EAN-13, UPC-A, ITF-14 and GS1-128 bar codes, so one of these must be used. The symbols used on very small products, the EAN-8 and UPC-E bar codes, will not generally be used on traded units.

Traded units may be handled automatically by goods inward and warehouse systems and so the bar codes must always be printed so that the bars of the symbol are upright when the unit

is in its normal storage position. Traded units will often be sold at a wholesale point of sale, and it is very important that the bar codes on the consumer units inside them cannot be scanned at these points of sale.

A minimum of one bar code is required, but two are recommended when the bar codes are pre-printed direct onto the outer packaging. This is because the cost of pre-printing an extra symbol is minimal, and should one bar code become damaged and unreadable,

the second one should still be scannable. When two symbols are provided, ideally one should be on a short side and the other on the adjacent long right hand side, but they can be placed on opposite sides if this means they will both remain scannable.

ITF-14 bar code with X-dimension of 0.635 mm

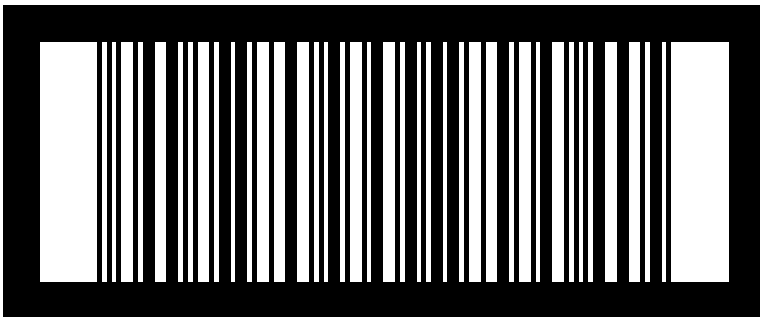

05012345678900

GS1-128 bar code with X-dimension of 0.50 mm

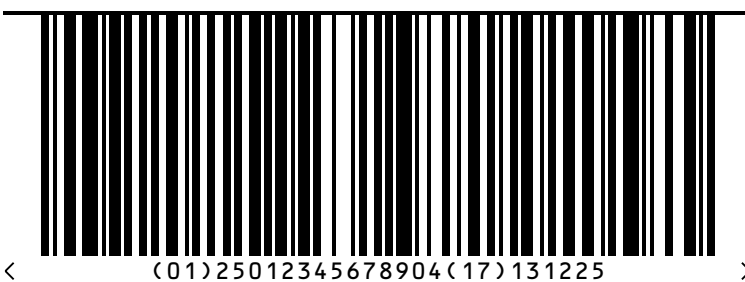

The data in this bar code provides the information that the GTIN is 25012345678904 and that the product's expiry date is 25 December 2013.





For logistics units, for example pallets

Scanners used to read labels on logistics units are designed to read GS1-128 bar codes.

All the bar codes on the pallet label must be GS1-128 bar codes.

- There must be two identical labels on each unit
- One label must be placed on a short side and the second label must be placed on an adjacent long side
- The bar codes including their Quiet Zones must be no closer than 50 mm to a vertical edge
- The minimum height of the bars of all the bar codes must be 32 mm. There is no maximum height for the bar code
- The bar codes must be upright, in picket fence orientation

If bar coded labels are being used, then one label is sufficient. This is because these bar codes are generally of a higher quality and will be scanned more reliably. This label should ideally be placed on one long side of the item.

- The bar codes on consumer units inside the outer case must not be scannable through the outer packaging
- The bar codes must be upright, in picket fence orientation, so that the bars are vertical
- The minimum height of the bars of the bar code must be 32 mm
- The bar codes including their Quiet Zones must be no closer than 19 mm to a vertical edge
- The bar codes must not be obscured by any final packaging

Bar code origination

Bar codes can be sourced as film masters, as digital EPS (encapsulated PostScript) files, or through the use of design software used in-house. Whichever method is used it is important to determine the correct size for the particular use of the bar code, and then the choice of substrate and printing technique.

More details are provided in appendix 4.

The use of verification equipment is recommended to check these master images, especially when artwork has been created digitally.

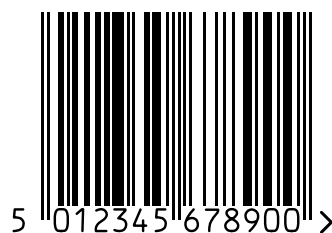



It is recommended that the bar codes on the finished products are then verified to ensure that all the production processes have resulted in a scannable bar code. Verification equipment meeting the requirements of ISO/IEC 15426-1 must be used as it will provide a check on all the important criteria.

More information about verification is provided in section 8.

This verification is strongly recommended because poor quality, unscannable bar codes create additional cost and delay for supply chain and point of sale operations.

Bar code colours

Bar codes must be printed so that the darker bars appear against a paler background. It is not possible to read a bar code if it is reversed out, that is, printed with white bars against a coloured background. Scanners detect the contrast between the bars and spaces using red light, and it is important to use colours that will maximise this contrast.

If using a semi-transparent substrate, do not rely on the colour of the contents of the packaging to provide a background colour: print a background in white, yellow, orange or red to provide adequate contrast with the bars of the symbol. Black bars on a white background are a good



combination, but other colours may be used provided the bars have a high blue, black or green content and are printed on a background that is white, yellow, orange or red. The illustrations overleaf show examples of scannable and non-scannable combinations of colour.

Verifiers that meet the requirements of the international specification ISO/IEC 15426-1 are able to measure the contrast of a printed bar code, and they must be used to check that particular colour combinations are scannable.

Any colours used for the printing of the bars must be pure colours, and not printed out of the conventional four colour process. It is not always necessary to introduce black as an extra colour to print the bars if one of the colours already used in the design will appear black under red light. Use a verifier compliant with ISO/IEC 15426-1 to check that the chosen combination will work effectively.





Bar code colours

Scanners use red light and only certain colour combinations can be used.

✓ Scannable

✗ Non-scannable



4. Choosing the correct bar code



The rules set out below will help you choose the correct bar code for each level of packaging.

1. If the product is a consumer unit (it could be sold at a retail point of sale), use an EAN-13, UPC-A, EAN-8 or UPC-E bar code to identify it.
2. If the product is a traded unit (a product that will not be sold at a retail point of sale), any of the GS1 bar codes may be used. However if bar codes are printed direct onto fibreboard packaging, ITF-14 symbols may need to be used.



3. If the traded unit could also be sold at a retail point of sale (for example, a box of 24 cans of beer), it must be bar coded with at least one EAN-13 or UPC-A at a magnification of at least 150%.¹
4. If EAN-13 or UPC-A symbols are printed on a traded unit, make sure that the packaging materials are of an adequate quality to allow for scannable symbols to be printed. The outer packaging of the traded unit must also obscure all the bar codes that appear on the products inside it.
5. If the traded unit has a short shelf life, say less than 42 days, use a GS1-128 bar code to encode the GTIN for the item and its expiry date. Most users will not be able to achieve a symbol of adequate quality unless they use print and apply labels or use white kraft board as the substrate.
6. If the traded unit has to be bar coded with extra information, such as a batch number or variant number, use a GS1-128 bar code to encode this information together with the GTIN.
7. If the traded unit is of variable measure, use a GS1-128 bar code, which will encode the measure (often the weight in kilograms) alongside the GTIN.
8. If pallets are being labelled, only GS1-128 bar codes must be used on the label.

¹In the past the term “magnification factor” was extensively used to specify the size of a bar code. This technique relied upon setting a nominal size (100 per cent) that was directly related to a given X-dimension. Since January 2000, the more precise term “X-dimension” has been used to specify permissible symbol sizes (see Appendix 2 on page 38)



5. Bar codes on consumer units



Consumer units (items that may be sold at a retail point of sale) must be bar coded with EAN-13, UPC-A, EAN-8 or UPC-E symbols, and they are shown here. In these examples the bar codes are shown at a size of 100%. Whenever symbols are made smaller or larger they must be kept in proportion. The height of the bars should not be reduced unless absolutely necessary as this makes the bar code more difficult to scan.

The UPC-A bar codes are the American equivalent of EAN-13 bar codes and occupy the same area as an EAN-13 bar code. They can be used in the UK and elsewhere with no problem.

The EAN-8 bar code represents a GTIN-8 number which is directly assigned by GS1 UK for the identification of very small items.

The UPC-E bar code is a special representation of a GTIN-12 number that would otherwise be shown in a UPC-A bar code symbol. These bar codes can be scanned in the UK but they are not generally available for UK users to create. Further information about these symbols is available in the GS1 General Specifications and from GS1 UK.

These four symbols – EAN-13, EAN-8, UPC-A and UPC-E – are sometimes referred to as EAN/UPC symbols. The bar codes have a nominal or 100% size which can be varied, and the size chosen will depend on the printing process and the quality of the inks and substrates being used. Appendix 2 lists the width and height of EAN-13 and EAN-8 bar code symbols at different sizes.

EAN-13
5 012345 678900 >

UPC-A
0 12345 67890 5

EAN-8
< 9609 3337 >

UPC-E
0 123456 5

All of these bar codes are at 100% magnification.



Main requirements

- The bars of the codes must not be shortened in height (truncated) unless the product's size makes this absolutely necessary
- Adequate light margins or Quiet Zones must be provided to the left and right of each bar code.
- The target size is 100% but the standards allow a range between 80% and 200%. However, keep them in the 80% to 120% magnification range if print quality allows.

When printing bar codes smaller than 100% remember that the printing tolerances are much tighter, and you must use high quality printing processes. It is not always possible to improve the quality of the printing process so tests must be carried out before committing to a particular size of symbol. If the consumer unit is also a traded unit, please see the next section for advice on the bar code's size.

X-dimension

When any of these bar codes is at its nominal or 100% size the width of the narrowest bar or space is 0.33 mm. This measurement is also known as the X-dimension or the module width, and this expression may sometimes be used to specify the size of a bar code. The width of the other bars and spaces is two, three or four times the X-dimension.

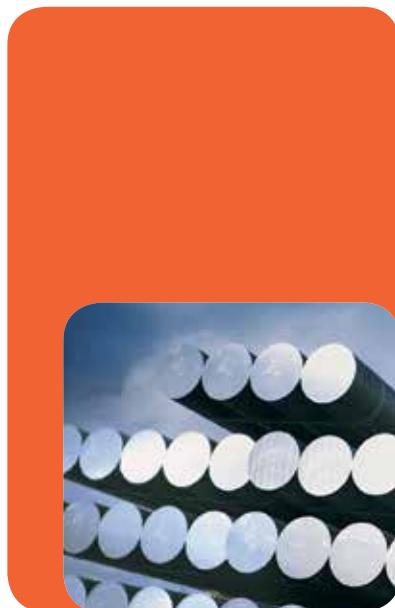

Quiet Zones

The clear spaces to the left and right of each bar code are very important as they are used by the scanner to determine where the bar code starts and finishes. These Quiet Zones must be the same background colour as the rest of the bar code and nothing must be printed in these areas except for the symbol's Quiet Zone indicators. These Quiet Zone indicators are optional, but they are strongly recommended to help safeguard the Quiet Zones.

The nominal dimensions for these Quiet Zones are provided in appendix 1, but it is important to allow slightly more than this space at each side to allow for variation in printing tolerances.



6. Bar codes on traded units



Traded units are sometimes called outer cases or trade item groupings. These traded units may cross a wholesale point of sale, and may also be scanned in automated goods handling systems and at goods receiving and despatch points. They are handled by manufacturers, distributors, transporters, wholesalers, and retailers. They usually contain a predefined number of consumer units, the items sold at a retail point of sale.

These items can be bar coded with EAN-13, UPC-A, ITF-14 or GS1-128 symbols depending on the type of outer case packaging material being used and the type of information required by trading partners.

Some products, such as washing machines, furniture and large multipacks, are both traded units and consumer units. If this is the case, the item number is the same for both uses. An EAN-13 or UPC-A symbol is required for the retail point of sale.

Using EAN-13 or UPC-A bar codes

If an EAN-13 or UPC-A bar code is printed on the packaging of a traded unit:

- The bar code must have a magnification of at least 150%, so that the width of the narrowest bars is at least 0.495 mm
- A minimum of one bar code is required, but two are recommended when the bar codes are pre-printed direct onto the outer packaging. If possible, one bar code should be on a short side and the other on the adjacent long right hand side.
- It must not be possible to scan any of the EAN or UPC bar codes on any of the items inside through the outer packaging. For further information see appendix 7
- The bar code must have Quiet Zones to the left and right, and the use of quiet zone indicators is strongly recommended as a means of safeguarding these
- The bar code must be upright, in picket fence orientation, so that the bars are vertical
- The bar code including its Quiet Zones must be no closer than 19 mm to a vertical edge

Examples of EAN-13 and UPC-A bar codes printed at a magnification of 150% are shown below:



EAN-13



UPC-A



ITF-14 bar code at nominal size

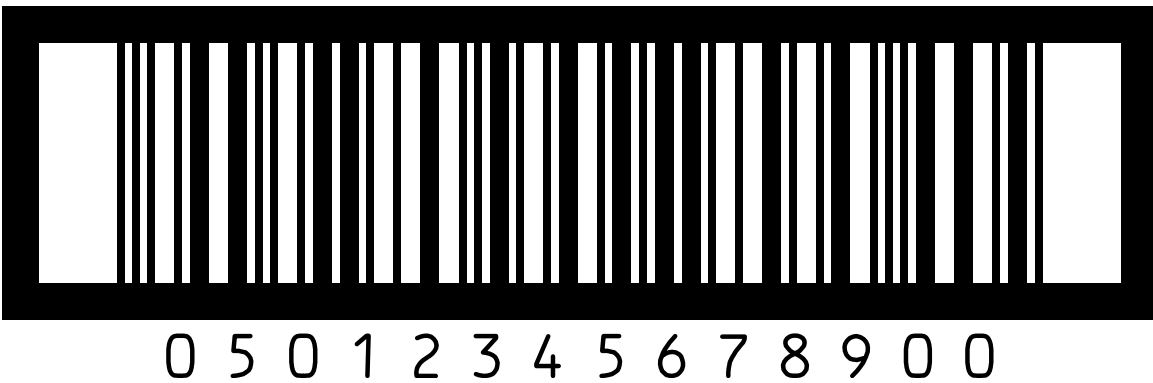

Using ITF-14 bar codes

It may be necessary to use ITF-14 symbols when bar codes are being printed directly on to fibreboard outer cases. If you have to provide extra variable information such as expiry dates or batch numbers, you will have to use GS1-128 bar codes which are explained below.

Examples of an ITF-14 symbol printed at its nominal size (equivalent to an X-dimension of 1.016 mm) and at reduced sizes with X-dimensions of 0.635 mm and 0.495 mm are shown alongside. Although the X-dimensions are smaller, the height of the bars remains at 32 mm, as shown here. As with the EAN/UPC symbols the aim is to print a scannable bar code within the specified size range.

ITF-14 bar code with X-dimension of 0.635 mm

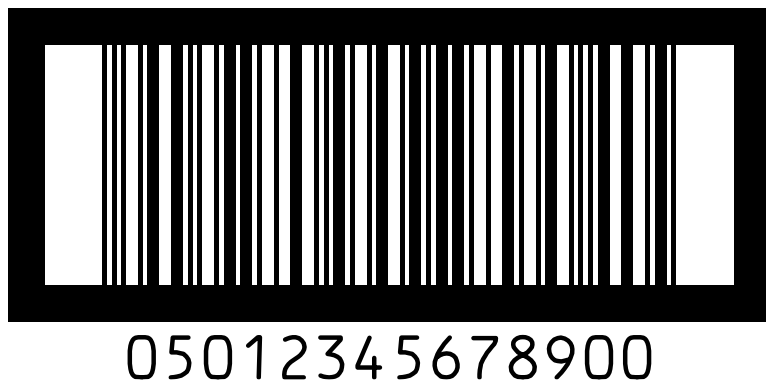

ITF-14 bar code with X-dimension of 0.495 mm

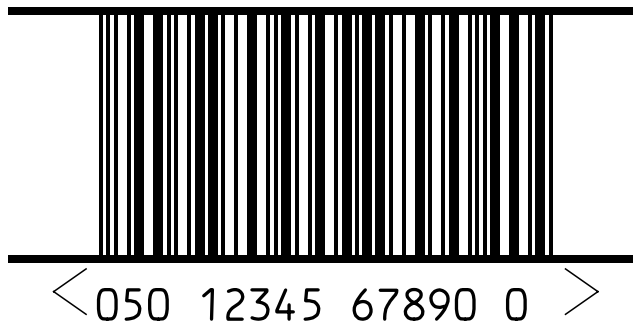



Using ITF-14 bar codes

Main requirements

- When printing directly onto fibreboard cases use symbols which have a maximum X-dimension of 1.016 mm
 - A minimum of one bar code is required, but two are recommended when the bar codes are pre-printed direct onto the outer packaging. If possible, one bar code should be on a short side and the other on an adjacent long side. Only one bar code is required if a label is used or the bar code is printed on demand
 - The bars must be 32 mm tall. This height is needed to help improve the performance of automated scanning systems
 - Clear Quiet Zones must be provided on both sides of the symbol
 - The wide to narrow ratio for the bars and spaces should be 2.5:1. The acceptable range is from 2.25:1 to 3.0:1.
- 
- The bar codes on the consumer units inside the outer case must not be scannable through the outer packaging. For further information see appendix 6
 - The bar codes must be upright, in picket fence orientation, so that the bars are vertical
 - The bar codes including their Quiet Zones must be no closer than 19 mm to a vertical edge
 - The minimum acceptable size for ITF-14 symbols is an X-dimension of 0.495 mm
 - Only use ITF-14 symbols with an X-dimension of less than 0.635 mm when printing on to labels, or directly on to high quality substrates; samples will need to be checked to ensure that these symbols are scannable

Bearer bars

The heavy box around the ITF-14 symbol is called the bearer box and it must always be included when pre-printing directly on to fibreboard materials.

If the ITF-14 symbol is printed using on-demand printing equipment it is only necessary to print the top and bottom bearer bars and these should have a width of at least 1 mm.

These bearer bars prevent any mis-scanning of the ITF-14 symbols, and help prevent the top and bottom of the bars from splaying apart when using flexographic printing plates. When these bar codes are printed on demand the bearer bar still prevents mis-scans and may also provide a visible check that all the print head elements are working.

Quiet Zone indicators

Quiet Zone indicators are not mandatory but are strongly recommended. Users of ITF-14 symbols must be confident that adequate Quiet Zones are being provided.

It is also important to check that the bar codes are not obscured by any final wrapping or treatment of the item.



Using GS1-128 bar codes

These bar codes, together with the application identifier standards, enable companies to provide additional information about a product alongside the GTIN for the product itself. These bar codes cannot be scanned at the retail point of sale so they are restricted to use on traded units.

These bar codes are recommended when it is necessary to be able to scan

- Use by and best before dates
- Measurements for variable measure products
- Batch and serial numbers

The different types of data must be specified by the application identifiers which appear before each data field. The brackets are only shown around the human readable numbers below the bar code. The brackets are not data and must not be encoded into the symbol. Full details about the choice of application identifiers are provided in appendix 5 and in the GS1 General Specifications which are available to GS1 UK members via the GS1 UK website at www.gs1uk.org.

The size of the GS1-128 bar code will depend on the amount of information it includes:

- Make sure no bar code, including its Quiet Zones, is longer than 165 mm
- If the bar code would be too long, use two or more bar codes to show the information

Main requirements

- A minimum of one bar code is required, but two are recommended if these are pre-printed direct onto the outer packaging. One bar coded label or one on-demand printed symbol is sufficient.
- When printing on labels, the minimum size is an X-dimension of 0.495 mm, which means the narrowest bars and spaces have a width of 0.495 mm
- When printing on fibreboard, use symbols which have an X-dimension of 1.016 mm

The bar codes on the consumer units inside the outer case must not be scannable through the outer packaging. For further information see appendix 6.

- The minimum bar height is 32 mm. This improves the performance of automated scanning systems
- The bar codes must be upright, in picket fence orientation, so that the bars are vertical
- The bar codes including their Quiet Zones must be no closer than 19 mm to a vertical edge





Bearer bars

These are not mandatory but are strongly recommended to highlight bar code printing problems. When GS1-128 bar codes are printed on demand in picket fence orientation any missing print head elements will show up as white gaps in the bearer bars at the top of the symbol. The use of bearer bars will help ensure accurate production of these symbols.

Quiet Zone indicators

Quiet Zone indicators are not mandatory but are strongly recommended. Users must be confident that sufficient Quiet Zones are provided at each side of the symbol. The diagram below provides an example of a suitable format for these.

When are brackets required around the application identifiers?

Brackets are used around each application identifier (AI) when the data is printed below the bar code. This makes it easier for people to read the AI and the data it defines. The brackets must not be encoded into the GS1-128 symbol itself.

Products with a shelf life of up to 42 days

In the UK many retailers expect shelf life dates to be bar coded on traded units that contain products whose shelf life is less than 42 days.

An example of a bar code for a short life product is shown below.

The AI 01 defines the GTIN for the product while the AI 17 defines the expiry date in the format YYMMDD. If a best before date is required, the AI 15 is used.



The data in this bar code provides the information that the GTIN is 25012345678904 and that the product's expiry date is 25 December 2013.



The GS1-128 bar code has Quiet Zones to the left and right which are also indicated by the optional quiet zone indicators. If the bar code is printed in picket fence orientation, the horizontal bearer bar will also make it easier to see if any of the print head elements are not working. If the code is printed in ladder orientation, any missing print head elements will show up as horizontal white lines across the symbol which will reduce its scannability. This is because the white lines will divide the symbol horizontally and make it unreadable by some scanners.

For further information about on demand printing, see appendix 4.

Variable measure products

When traded units contain catch weight items (items that do not have a predefined weight), then the net weight of the contents must be shown in a GS1-128 bar code. Other variable measures such as length, area and volume can be shown using different application identifiers, but weight is the most common measure used in the UK. For further details about the other application identifiers, see chapters 3 and 4 of the GS1 General Specifications.

- Use the AI 3102 to give the net weight in kilograms to two decimal places. Other AIs can be used to give weight to a different number of decimal places
- The GTIN must be a 14 digit number beginning with 9

The data in this bar code provides the information that the GTIN is 95012345678903, that the product's net weight is 12.75 kilograms, and that the expiry date is 25 December 2013.

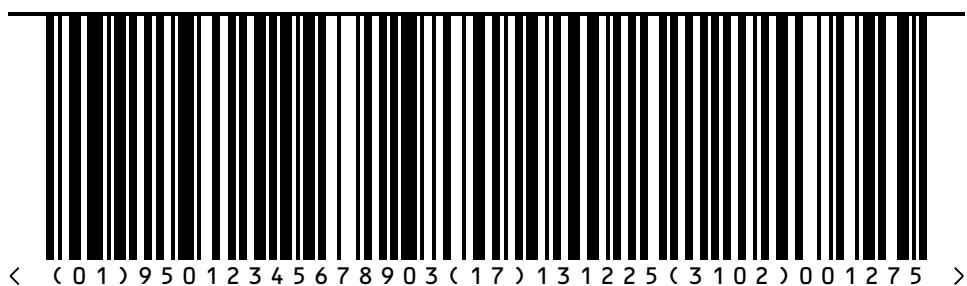

7. Pallet labels



Pallets and other transport units must be labelled with a GS1 logistics label and an example of one is given on page 22.

For further information about using pallet labels, see the GS1 Standard International Logistic Label (STILL) guideline available via the GS1 UK website, www.gs1uk.org.

The X-dimension for the GS1-128 bar codes shown in the example is 0.495 mm, and this is the minimum size that should be used.

The GS1 General Specifications stipulate that GS1-128 bar codes must be used on these labels to represent the GS1 defined data.

The most common label size is close to A5 which is 148 mm wide and 210 mm tall. If less information is required, some companies will choose to use a label size close to A6 which is 105 mm wide and 148 mm tall. The actual size of the label will depend on the requirements of the particular value chain, and any size of label may be used.

The label uses GS1-128 bar codes and provides information that will be useful to all the participants in the transport and distribution chain.

- Each shipping container, transport unit or pallet is identified with a unique tracking number called a serial shipping container code or SSCC
- The SSCC is an 18 digit number that is unique for each unit
- The SSCC is denoted by the AI 00
- The bar code containing the SSCC must always be the lowest bar code on the label



In addition to the SSCC most users will provide details of the contents of the pallet.

- Use AI 02 to give the GTIN of the cases on the pallet together with AI 37 to provide a count of the cases
- Only use AI 01 to give a GTIN for the pallet if the pallet has a pre-defined configuration, and it is a traded unit. AI 01 must not be used together with AIs 02 and 37
- Use whichever extra AIs you need to provide extra information for yourself or your trading partners, for example AI 10 for batch number
- The height of the bars of all the bar codes must be a minimum of 32 mm
- Bearer bars should be used to give an indication of print head failure





A5 sized label

THE COMPANY LIMITED

ANY ADDITIONAL INFORMATION

SSCC

050123450001234563

Content

15012345678907

Count

110

Use by

25.12.13

Batch No.

1234AB

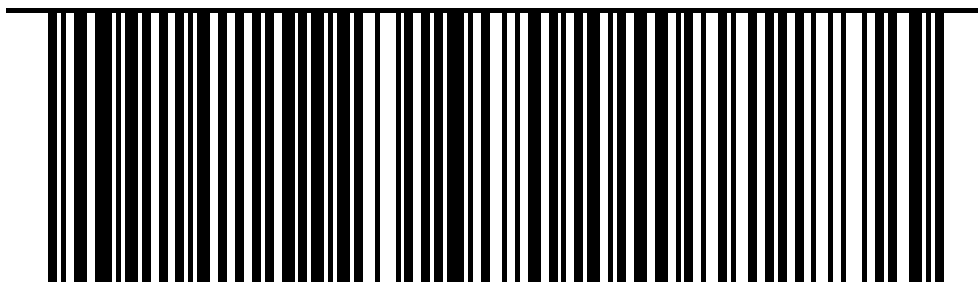

< (02)15012345678907(17)131225(37)0110 >

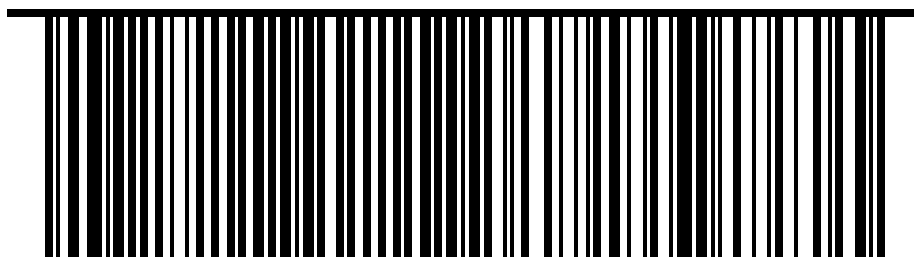

< (00)050123450001234563(10)1234AB >



Position of label on pallet

Many pallets will be handled on automatic systems so it is recommended that the label should be applied on the right hand side of the permitted area for best use of scanning.*

For pallets taller than 1,000 mm

- Place the label so that the bar codes are no higher than 800 mm and no lower than 400 mm
- Use two identical labels for each pallet, one on a short side and one on a long side as shown below
- Ensure that the bar codes including their Quiet Zones on the label are no closer than 50 mm to a vertical edge

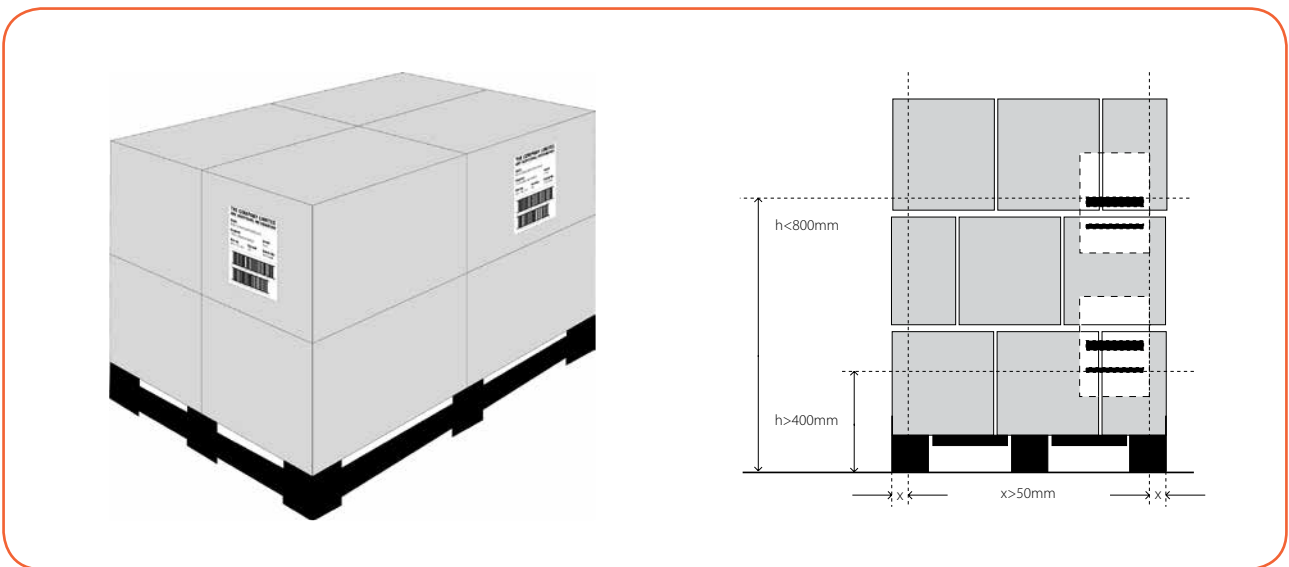

For pallets lower than 1,000 mm

- Place the label as high as possible but make sure that the bar codes are no higher than 800mm and no lower than 32mm from the base of the unit
- Ensure the bar codes with their Quiet Zones are no closer than 50 mm to a vertical edge

*GS1 UK Best Practice Logistics Label Guidelines

8. The verification process



The accurate printing of bar codes is fundamental for effective value chain management as the rapid and accurate scanning in of GS1 data provides the basis for all the electronic business transactions that follow.

Bar code scanning provides no indication of bar code quality as it gives no information about the symbol other than whether it can be scanned or not by that particular scanner. Scanners look for sufficient contrast between the bars and spaces, and decode the different widths of bars and spaces into data that is sent to the software for processing.

The GS1 General Specifications describe a process for the production of bar codes that should result in scannable symbols, but a verification procedure needs to be followed to provide more information about symbol quality.

Staff need to be trained in the use of verification equipment, and must always check symbols visually before using a verifier that meets the requirements of ISO/IEC 15426-1 to provide detailed information. Each symbol must be checked to see that the bars are the correct height, and that no horizontal lines or spaces cut through the symbol. Any marks crossing the bars and spaces of a symbol will reduce its effective height and make it very difficult to scan.

The position of the bar code on the packaging will need to be checked to see that it meets the GS1 General Specifications. Any final labelling or wrapping should also be examined to ensure that the bar codes remain visible and scannable.

When checking symbol quality, you should attempt to simulate the final, filled product or package. If for example a white background is printed on to a clear substrate, check the colour of the contents of the item. If it is not possible to simulate the contents, verify the bar code twice, once over a black background and next over a white background. The worse of the two grades will provide information about the worst possibility.



Having checked that the bar codes are in the correct position and are not shortened in height (truncated), you can use verification equipment to obtain an overall grade for each symbol.





Verifiers that meet the international requirements will measure and grade the following seven parameters of the code:

- The symbol contrast (a measure of the contrast difference between the dark bars and the paler background)
- The minimum reflectance (a check that the bars appear dark enough in relation to the spaces)
- The minimum edge contrast (a measure of the least difference in contrast between an adjacent bar and space). This will be a low grade if the bar code is unlikely to be read when it is scanned
- Modulation (a ratio of the minimum edge contrast to the symbol contrast). This grade will be low if positive bar gain has increased the width of the bars causing a narrowing of the spaces between them
- Defects (which may be light voids within dark bars or dark spots in the spaces between the bars)
- Decode (an indication that the symbol will decode successfully if it conforms to the specifications, notably in respect of character encodation, check digits and Quiet Zones)
- Decodability (an indication of the accuracy of widths and positions of the bars and spaces)

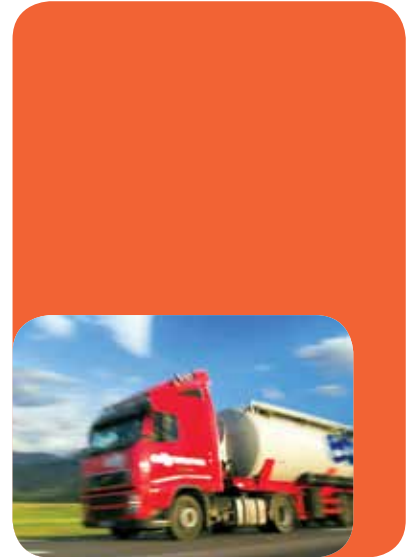

All of these criteria are measured separately and the grade given to the bar code is the lowest score for any one of these measurements.

All of these characteristics can be measured by verification equipment which meets the requirements of ISO/IEC 15426-1, which incorporates the CEN (Comité Européen de Normalisation, the European Standards Committee) standards. These standards are compatible with those from ANSI (the American National Standards Institute) and the table below shows how they compare.

ANSI to ISO Grade Conversion Table

A	–	3.5 to 4.0
B	–	2.5 to 3.4
C	–	1.5 to 2.4
D	–	0.5 to 1.4
F	–	Less than 0.5



This standard applies to all the ID/Linear bar codes used by the GS1 System, and provides a basis for agreeing with trading partners the quality of symbols that will be accepted. The verifier should ideally be used to check each symbol being tested ten times, using different paths through the symbol. Higher grades mean that the bar code in question is closer to the ideal than lower scoring symbols, but there may still be some faults that will prevent it from being decoded successfully by all scanners.

The aim is to produce bar codes with grades 4 or A, although this will be difficult with some printing processes and materials.

All bar codes must be grade 1.5 or C or above, except for ITF-14 symbols printed on to fibreboard, when grade 0.5 or D is acceptable.

In general, higher quality bar codes can be expected to scan more easily and quickly than lower quality bar codes of the same size. Bar codes of similar sizes, with no reduction in height (truncation), and high print quality contribute to fast, effortless scanning.



Traditional verification

The traditional approach to testing print quality, PCS or print contrast signal, is no longer formally specified by GS1 but it is still a useful means of obtaining information about the bar code. Most verification equipment will be able to report these parameters:

- The width, magnification or X-dimension of the bar code
- Dimensional bar width deviations, in particular a figure for average bar growth
- Dimensions of the Quiet Zones at each side of the code
- Print contrast signal. This compares the amount of light reflected from the bars to the amount of light reflected by the spaces and measures it as a percentage of the light from the spaces. It is a different measure from symbol contrast



9. Common problems to avoid



These are many of the most common problems, and some that will be discovered with the correct use of verification equipment.

Pictures of problems	Problems
----------------------	----------

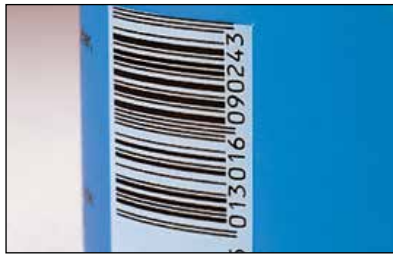

The Quiet Zones required for each bar code are not large enough.



The bar codes are shortened below their standard height (known as truncation).



Missing bars or horizontal white lines crossing the bar code because of faulty print heads used for on demand printing.



Choosing incorrect colour combinations, often orange or red bars on a pale background, which will not scan. Reversed out images, where the bars are white against a coloured background, are again not scannable.



Using transparent or semi-transparent substrates, such as glass or plastic, and hoping that the contents will provide a suitable background colour either for the bars or the spaces.



Pictures of problems

Problems



Printing bar codes that are either too large or too small.



Incorrect adjustment for ink spread (the bar width reduction). The printed bars are out of specification, either being too narrow or too wide.



Placing labels too close to vertical corners or wrapping them around corners so that the bar codes are too close to the edge.



Peeling or creased labels.



Show through of the bar codes on consumer units through the outer packaging.





Pictures of problems

Problems



Printing bar codes onto film which is distorted as it is used as shrink wrap.



Obscuring the bar codes.



Bar code printed vertically on a traded unit.



Bar code printed too close to edge of label.



Pictures of problems

Problems



Same GTIN on different product lines.



Printing bar code on to packaging or a label which is then distorted.



Poor quality substrates are substituted for the original specification, resulting in loss of quality, often greater ink spread, or the appearance of voids in the bars. A darker coloured substrate, for example, could result in insufficient contrast.



Using uncovered metal surfaces as a background or for the bars of a symbol. The specular reflectance of the substrate can cause problems, and a solid background must be printed to provide good contrast and eliminate this problem.

Problems with GS1-128 bar codes

Printing Code 128 symbols instead of GS1-128 symbols because the mandatory Function 1 character is not included.

Encoding the brackets around the application identifiers as data within a GS1-128 bar code. These brackets are only used around the application identifiers in the human readable characters printed below the bar code.

Printing a GS1-128 symbol wider than 165.1 mm. This dimension includes Quiet Zones which are not explicitly indicated, so special attention must be given.

Not showing the application identifiers in brackets below a GS1-128 bar code.

Not including the application identifiers required to define the data in a GS1-128 bar code.



10. Checklist



Re-check the GTIN and check this and other encoded data in any artwork

- ✓ Ensure that the check digit is correct.
- ✓ Ensure that the correct symbol is used for the relevant product, application and scanning environment.
- ✓ Check the size of the symbol, both the magnification and the bar height.
- ✓ Check the position of the symbol on the final, made-up product.
- ✓ Ensure that there are adequate Quiet Zones and that any optional quiet zone indicators are correctly placed.
- ✓ Check that the contrast between the bars and the background is adequate and that the colours chosen will scan. Make sure that the colour of the contents of the packaging will not unduly affect the contrast between the bars and spaces.
- ✓ Check the print quality regularly throughout the print run by verifying symbol quality.
- ✓ Check that the bar code will remain readable in the environment in which the product will be stored, handled and distributed.
- ✓ Ensure that no shrink-wrap, tape or other printing will obscure the bar code on the finished product.
- ✓ Ensure that no other bar code will show through from the inside of the pack.
- ✓ Carry out routine verification at all levels of packaging to ensure that the bar code complies with the required quality standard, and to identify any potential problems.
- ✓ Keep records of verification for the shelf life of the product.
- ✓ Notify trading partners of the GTINs and the products they identify in good time.

11. Summary of best practice recommendations



	EAN-8, EAN-13, UPC-E and UPC-A	ITF-14 printed on label	ITF-14 pre-printed on board	GS1-128
Consumer unit	✓	✗	✗	✗
Traded unit	✓ (except UPC-E and EAN-8)	✓	✓	✓
Traded unit with short shelf life				✓
Number of bar codes on consumer unit	1			
Number of bar codes on traded unit	2 ¹	1	2	1
Range of X-dimension sizes	0.264 mm to 0.66 mm ²	0.495 mm to 1.016 mm	0.635 mm to 1.016 mm	0.495 mm to 1.016 mm
Magnification range	80% to 200% ³	48.7% to 100%	62.5% to 100%	48.7% to 100%
Target size for consumer units (X-dimension in mm)	100% (0.33 mm)			
Target size for traded units (X-dimension in mm)	150% (0.495 mm)	48.7 % (0.495 mm)	100% (1.016 mm)	48.7 % (0.495 mm)
Target bar height for 100% sized EAN/UPC symbols	For EAN-13, UPC-A and UPC-E, 23 mm. For EAN-8, 18.5 mm			
Absolute minimum bar height for consumer units ⁴	16 mm			
Minimum bar height for traded units	32 mm	32 mm	32 mm	32 mm
Bearer bar	NO	YES	YES	YES
Optional Quiet Zone indicators ⁵	YES	YES	YES	YES
Minimum verification grade	C	C	D	C

¹ A minimum of one EAN/UPC symbol is required when the traded unit is also a consumer unit.

² A minimum X-dimension of 0.25 mm is allowed for on-demand bar code production.

³ A minimum magnification of 75.8% is allowed for on-demand bar code production.

⁴ Any shortening in the height of bar codes may cause problems and might be unacceptable outside the UK.

⁵ Quiet Zone indicators are not formally required but they may be used to provide a visual indication of the space required to the left and right of each symbol.





1. Ensure EAN-13, UPC-A, EAN-8 or UPC-E bar codes are used on any product that might be sold at a retail point of sale.
2. If a traded unit might also be sold at a retail point of sale, it must be bar coded with an EAN-13 or UPC-A bar code of at least 150% magnification (equal to an X-dimension of at least 0.495 mm). The actual size chosen will depend on the choice of printing materials being used.
3. Traded units can be bar coded with any of these symbols – EAN-13, UPC-A, ITF-14 and GS1-128. Short shelf life traded units (those with a shelf life of less than 42 days) will need to be bar coded with a GS1-128 bar code including the expiry date.
4. Remember that the Quiet Zones of any of the bar codes vary in proportion when you increase or decrease their size. Ensure that the Quiet Zones you provide at each side of the bar code will be adequate, and it is good practice to allow at least 1 or 2 mm extra on each side to allow for any variation in the printing.
5. When printing any of the GS1 bar codes on demand, incorporate horizontal bearer bars that will allow you to see easily whether any print head elements are failing.
6. Make sure it is not possible to scan any of the bar codes on individual items when they are inside any outer packaging.
7. The areas needed for the bar codes at their target sizes are as follows:

Bar code	Magnification (x-dimension)	Quiet Zone width needed on each side*	Space needed (width x height)*
EAN-13	100% (0.33 mm)	6 mm (left), 4.5 mm (right)	42 mm x 26 mm
UPC-A	100% (0.33 mm)	5 mm	42 mm x 26 mm
EAN-8	100% (0.33 mm)	4.5 mm	31 mm x 22 mm
UPC-E	100% (0.33 mm)	5 mm (left), 4.5 mm (right)	27 mm x 26 mm
ITF-14 on label	48.7% (0.495 mm)	7 mm	75 mm x 49 mm
ITF-14 on board	100% (1.016 mm)	12.5 mm	160 mm x 49 mm
GS1-128 showing GTIN and a date on a label	48.7% (0.495 mm)	7 mm	103 mm x 40 mm
GS1-128 showing GTIN and a net weight and a date on a label	48.7% (0.495 mm)	7 mm	131 mm x 40 mm

*These dimensions include an extra 2 mm to the minimum required on each side of the bar code to ensure that adequate Quiet Zones are provided.

12. Bar code management



It is good practice to assign the role of symbol quality manager to a specific individual in the organisation. Depending on the type of organisation, retailer or manufacturer, the use of bar codes will differ, which will affect the specific role of the assigned manager. However, their primary objective will be the same, to ensure good quality bar codes.

For a retailer the manager will ensure that the symbols scan properly at the retail or wholesale checkout and at the distribution centre.



A symbol quality manager for a manufacturer will ensure that good quality bar codes are accurately and consistently applied to products.

13. Glossary of terms



Terms	Meaning
Application identifier	The two, three or four digit number that specifies the data that immediately follows it in a GS1-128 bar code.
Article number	The former name for the global trade item number.
Bearer bars	Horizontal bars printed above any of the bar codes when they are printed on demand that will indicate any missing printhead elements. Also used above and below ITF-14 bar codes to prevent short scans.
Bearer box	The bars that surround an ITF-14 symbol to equalise the pressure exerted by the flexographic printing process over the entire surface of the symbol.
Check digit	The last digit of an identifier that is calculated from all the preceding digits to check that the data has been correctly composed.
Consumer unit	An item that may be sold at a retail point of sale. Also referred to as a retail trade item.
EAN-8	The eight digit bar code that represents a GTIN-8.
EAN-13	The thirteen digit bar code that represents a GTIN-13.
EAN/UPC	The name of the symbology used by EAN-8, EAN-13, UPC-A and UPC-E bar codes.
GTIN	Global trade item number. The unique number for a product line. This number identifies items or services that are priced, ordered or invoiced at any point in the supply chain.
GTIN-8	The name given to the eight digit GTIN that may be shown in an EAN-8 bar code.
GTIN-12	The name given to the twelve digit global trade item number formed from a UPC company prefix number. This may be shown in UPC-E, UPC-A, ITF-14 and GS1-128 bar codes.
GTIN-13	The name given to the thirteen digit GTIN that may be shown in EAN-13, ITF-14 or GS1-128 bar codes.
GTIN-14	The name given to the fourteen digit GTIN that may be shown in either ITF-14 or GS1-128 bar codes on traded units.
GS1	The global body for GS1 member organisations which administers the GS1 system.
Item number	Global trade item number.
ITF-14	A 14-digit interleaved two of five bar code. The bar code may be used to show GTIN-12, GTIN-13 and GTIN-14 numbers on trade items not crossing a retail point of sale.
Kraft	A type of fibreboard often used for outer cases.
Ladder orientation	Printing the bar code so that the bars are parallel to the base of the product.
Light Margins	No longer used as a reference term now known as "Quiet Zones"



Terms	Meaning
Quiet Zone indicators	Marks to indicate the Quiet Zones required.
Logistics unit	A unit, for example a pallet load, which is constructed for moving goods from one place to another.
Quiet Zone	A clear space required to the left and right of any bar code formerly known as “Light Margins”. These differ for each bar code as shown in Appendix 1.
Magnification	The factor used to vary the nominal size of each bar code to ensure it is scannable.
Module	The smallest element (i.e. thinnest bar or space) of a bar code.
Outer case	A kind of traded unit.
Pallet label	The GS1 logistics label that is used to track and identify pallets loads or any other transport units.
Picket fence orientation	Printing a bar code so that the bars are perpendicular to the base of the product.
SSCC	Serial shipping container code. The unique eighteen digit identifier for a transport unit.
Specular reflectance	The reflectance of light from highly polished surfaces.
Substrate	The material on to which a bar code is printed.
Symbology	A type of bar code symbol.
Trade item	Any item that is identified for pricing, ordering and invoicing purposes. This includes both consumer units and traded units.
Traded unit	An item that is priced, ordered and invoiced between manufacturers, retailers and wholesalers. Also known as an outer case or a trade item grouping.
Logistics unit	A unit, for example a pallet load, which is constructed for moving goods from one place to another.
Truncation	The reduction in height of a bar code when its width is unaltered.
UPC-A	Universal Product Code, version A. The name for the 12 digit bar code that represents a GTIN-12.
UPC-E	Universal Product Code, version E. The name for the eight digit bar code that represents a GTIN-12 with zero suppression.
X-dimension	The nominal width of the narrowest bars or spaces in a printed bar code.
Zero suppression	Used by eight digit UPC-E symbols to represent a twelve digit global trade item number.



Appendix 1



Bar code dimensions

Nominal (100% magnification) dimensions of EAN/UPC and ITF-14 bar codes. All measurements are in millimetres.

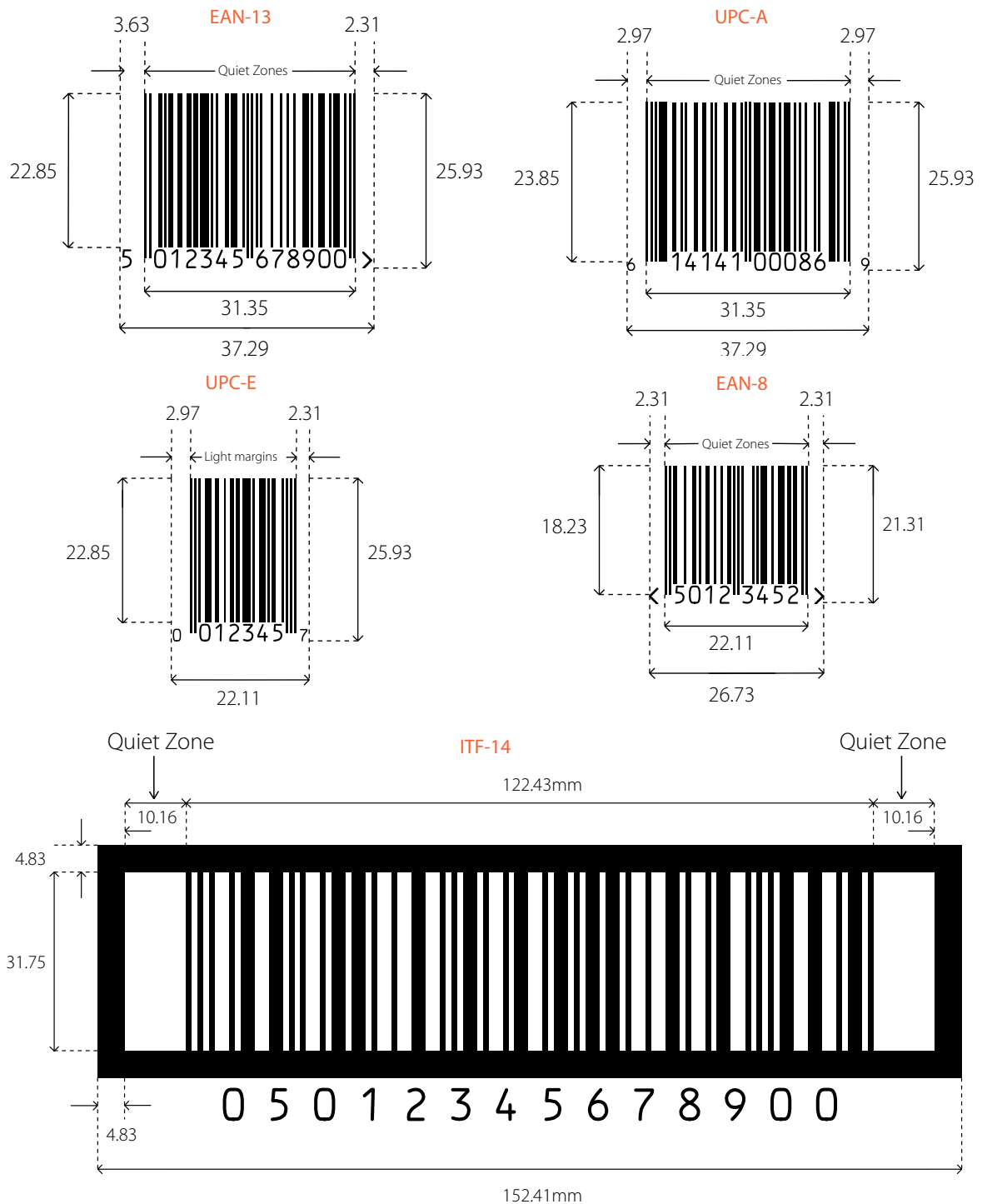

The Quiet Zone dimensions shown here are the minimum for nominal sized symbols and in practice extra space must be provided to allow for printing variations. These Quiet Zones also change in proportion with any increase or decrease in the magnification of these symbols.

Appendix 2



GS1 Bar code specifications

Dimensions of EAN-13 bar codes at different sizes

Magnification factor	*X-Dimension	EAN-13/UPC-A Dimensions (mm)		EAN-8 Dimensions (mm)	
		Width	Height	Width	Height
0.80	0.264	29.83	18.28	21.38	14.58
0.85	0.281	31.70	19.42	22.72	15.50
0.90	0.297	33.56	20.57	24.06	16.41
0.95	0.313	35.43	21.71	25.39	17.32
1.00	0.330	37.29	22.85	26.73	18.23
1.05	0.346	39.15	23.99	28.07	19.14
1.10	0.363	41.02	25.14	29.40	20.05
1.15	0.379	42.88	26.28	30.74	20.96
1.20	0.396	44.75	27.42	32.08	21.88
1.25	0.412	46.61	28.56	33.41	22.79
1.30	0.429	48.48	29.71	34.75	23.70
1.35	0.445	50.34	30.85	36.09	24.61
1.40	0.462	52.21	31.99	37.42	25.52
1.45	0.478	54.07	33.13	38.76	26.43
1.50	0.495	55.94	34.28	40.10	27.35
1.55	0.511	57.80	35.42	41.43	28.26
1.60	0.528	59.66	36.56	42.77	29.17
1.65	0.544	61.53	37.70	44.10	30.08
1.70	0.561	63.39	38.85	45.44	30.99
1.75	0.577	65.26	39.99	46.78	31.90
1.80	0.594	67.12	41.13	48.11	32.81
1.85	0.610	68.99	42.27	49.45	33.73
1.90	0.627	70.85	43.42	50.79	34.64
1.95	0.643	72.72	44.56	52.12	35.55
2.00	0.660	74.58	45.70	53.46	36.46

Note: The magnification of the bar code will be determined by the printing process chosen for your packaging. Please check this with your printer.

For further information please refer to GS1 General Specifications, the latest version is available on the GS1 UK website.

*The width of the smallest bar or space is called the X-Dimension; all other elements are multiples of this dimension.



Appendix 3



Creating GTINs and SSCCs

Companies wishing to bar code their products for open trade will need to join a GS1 member organisation to be assigned a company prefix number that can be used to create global trade item numbers (GTINs), serial shipping container codes (SSCCs), or any of the other GS1 identifiers. The UK member organisation is GS1 UK.

Companies joining GS1 UK will be given a GS1 company prefix number beginning with the numbers 50. Other member organisations allocate company prefix numbers beginning with different numbers.

Companies will be allocated different length company prefix numbers according to their numbering requirements. Company prefix numbers from GS1 UK are 5 to 11 digits in length and they will be used to create 13 or 14 digit GTINs and 18 digit SSCCs.



Global trade item numbers (GTINs)

GTINs are unique numbers that are used to identify every different product line. GS1 company prefix numbers can be used to create 13 and 14 digit GTINs, and UPC company prefix numbers can be used to create 12 and 14 digit GTINs. Every user should ensure that their database can record 14 digit GTINs as these numbers may be used on products that are supplied to them, even if a user decides not to create 14 digit numbers. This is especially important as future developments may include a 14 digit option for the retail point of sale.





Creating GTIN-13s

The most commonly used bar code represents 13 digits and is called an EAN-13 bar code. The standard thirteen digit number is called a GTIN-13 and is made up as follows:

It is your responsibility to allocate item reference numbers. Basically every different product line (whether a single item or a box of them) requires a different number. The numbers have no meaning so



Company prefix number	Item reference	Check digit	Number of item numbers that can be created
XXXXXXX	XXXXX	C	100,000
XXXXXXXX	XXXX	C	10,000
XXXXXXXXX	XXX	C	1,000

Company prefix numbers allocated by GS1 UK will begin with 50, but 50 does not imply anything about the origination of the product being identified.

You create these 13 digit numbers by adding the item reference digits to your company prefix number, and by calculating a final check digit. If you have a seven digit prefix number, you add five digits before calculating the check digit. If you have an eight digit prefix number, you add four digits, and if you have a nine digit prefix number, you add three digits.

The calculation for the check digit is provided at the end of this appendix, and a check digit calculator is also available on the GS1 UK website at www.gs1uk.org.

it will often make sense to start with 00000, 00001, 00002, and so on until 99999 is reached if you have a seven digit prefix number. For eight and nine digit prefix numbers, you should start with 0000, 0001, 0002 and 000, 001, and 002 respectively.

My Numberbank in the member area of the GS1 UK website provides you with a facility to manage your allocation of GTINs (and other identifiers). It provides competed GTINs, including check digits, from your company prefix and also enables production of corresponding bar code images.





Creating GTIN-12s

If you are trading with companies based in North America you may be using UPC bar codes for your products. These represent GTIN-12s which can only be created with a UPC company prefix number which you will have specially requested and paid for. The table below shows how GTIN-12s are created in exactly the same way as GTIN-13s.

UPC prefixes being allocated to organisations now will generally begin with 6, 7 or 8, but some users will have prefixes that begin with 0. All of these prefixes must be used to create complete

12-digit numbers. The check digit calculator that is available on the GS1 UK website, www.gs1uk.org, will give you the option of choosing GTIN-12 for this calculation.

Company prefix number	Item reference	Check digit	Number of item numbers that can be created
XXXXXX	XXXXX	C	100,000
XXXXXXXX	XXXX	C	10,000
XXXXXXXXXX	XXX	C	1,000

Creating branded variable measure restricted circulation numbers (RCNs)

Products which are not fixed in weight and are sold at a retail point of sale are bar coded using branded variable measure prefix numbers which are available on request from GS1 UK. These special prefixes are only used on items which vary continuously in any

measure that affects their price, and this will often be their weight. These 13 digit RCNs include their price in sterling and cannot be used in other currency areas. Companies exporting these products should contact GS1 UK for details of the equivalent systems used abroad.

The first seven digits of this number will be notified to the retailer selling these items, and are known as the short identification number. The price verifier is calculated according to an algorithm explained in the GS1 General Specifications and uses the four digits representing the price. The check digit is calculated in the normal way.

These numbers are constructed as follows:

Branded variable	Item reference	Price verifier	Price in sterling	Check digit
20XXX	XX	V	PPPP	C

The EAN-13 bar codes representing these RCNs are printed at the weighing station and the selling price per unit of measure must be known before the labelling can begin.

Creating own-label variable measure restricted circulation numbers (RCNs)

Own-label variable measure RCNs will be used by retailers selling products under their own name in their own stores. These cannot be used in open trade. The structure

generally adopted in the UK is as follows, but some retailers may choose not to include a price verifier.

The price verifier is calculated using the five digits that precede the check digit. These RCNs are shown in EAN-13 bar codes.

Internal item reference	Price verifier	Price in sterling	Check digit
02XXXX	V	PPPPP	C



Creating GTIN-14s

Any member company can choose to identify their traded units (trade item groupings) with GTIN-12, GTIN-13 or GTIN-14s. Some companies will use GTIN-14s for outer cases, and they must be shown using either ITF-14 or GS1-128 bar codes.

The numbers are created by adding an indicator as a prefix to the GTIN-13 for a product, and then recalculating the check digit as shown below. The indicator can take any value from 1 to 8, and simply creates a different item number for a different packaging configuration. (The number 9 is only ever used when identifying outer cases of products of a continuously variable measure, usually weight.) The indicator has no meaning so all the details of the item being identified in this way must be given to your trading partners in the normal way.



Component parts of GTIN-14

Organisations using these GTIN-14 numbers can increase their numbering capacity significantly, but please remember that they must only be used on trade item groupings.

Indicator	GTIN-13 of single item without its check digit	New check digit
1	501234567890	7
2	501234567890	4
3	501234567890	1
4	501234567890	8
5	501234567890	5
6	501234567890	2
7	501234567890	9
8	501234567890	6

Companies using UPC company prefix numbers can also use this approach to create GTIN-14 numbers, but a zero will need to be placed after the indicator as a filler character. This will then convert a GTIN-12 into a new GTIN-14.

Many companies will decide not to use this basis for creating GTINs, but all systems must be able to record these 14 digit item numbers.

Creating SSCCs

The same company prefix number used to create GTINs is used to create serial shipping container codes (SSCCs) that are unique serial numbers for each logistics unit. Companies that have a seven digit GS1 company prefix number can create up to ten billion different SSCCs. Users with longer company prefix numbers have fewer numbers to use, but they will still create unique 18 digit numbers.





The number has four components but it must always be used as one complete number within companies' computer systems. Whenever the SSCC is shown in a GS1-128 bar code it will be preceded by the application identifier 00.

Application identifier	Extension digit	Company prefix number	Serial number	Check digit
00	X	XXXXXXX	XXXXXXXXXX	C
00	X	XXXXXXXXXX	XXXXXXXXXX	C
00	X	XXXXXXXXXX	XXXXXXX	C

The application identifier (AI) for SSCCs is always 00, and determines the data structure.

The extension digit can take any value between 0 and 9 and allows users to create more SSCCs.

The number of digits in the serial number depends on the length of the company prefix number, and is allocated by the company making up the unit. The number must not be reused for at least one year.

A UPC company prefix number will be prefixed with a zero when used to create SSCCs.

Check digit calculation

The last digit of any GTIN or SSCC is a computer check digit to make sure the number is correctly composed. The check digit is calculated by a modulo 10 algorithm from all the other digits in the number through the following steps:

1. Starting with the digit on the right of the number, (excluding the check digit) sum all the alternate digit values, reading right to left.
2. Multiply the result of step 1 by 3.
3. Sum all the remaining digit values.
4. Add the result of step 2 to the result of step 3.
5. The modulo-10 check digit is the smallest number, which when added to the result of step 4, produces a multiple of 10.

For example, to calculate the check digit for the GTIN-13 number 501234576421_:

5 0 1 2 3 4 5 7 6 4 2 1 _

Step 1 $1 + 4 + 7 + 4 + 2 + 0 = 18$

Step 2 $18 \times 3 = 54$

Step 3 $2 + 6 + 5 + 3 + 1 + 5 = 22$

Step 4 $54 + 22 = 76$

Step 5 $76 + C = 80$

ANSWER $C = 4$

The complete GTIN-13 number is

5 0 1 2 3 4 5 7 6 4 2 1 4

A series of check digit calculators is available on the members' area of the GS1 UK website, www.gs1uk.org. They will produce check digits for all the numbers mentioned here.

Appendix 4



Printing techniques

Virtually all consumer units (products that will be sold at a retail point of sale) and very many traded units (the outer cases for the consumer units) will be sold in packaging that is printed with the appropriate bar code. Some items will use bar coded labels and advice about using these is provided in the second section of this appendix.

The image of the bar code that is included in the artwork will need to be adjusted to take account of the spread of ink. This is necessary because direct contact printed bars in bar codes print wider than the actual width of bars on the printing plate. The difference between the width of the bar as it is printed and the specified width on the printing plate is called print gain.

Each bar on the printing plate needs to be reduced in width by the average print gain and this is known as bar width reduction.

All widths of bar have the same bar width reduction so that the spaces on the printing plate will be wider than they will be when they are printed. This adjustment in the width of the bars can be determined by the use of the printability gauges. Many printers will be able to offer advice about the use of the printability gauges and will obtain images that have been correctly adjusted for the particular printing process being used.

Different printing techniques have different tolerances for printing accuracy and different print gains so it is important to check what these are before choosing a particular size of bar code. The choice of substrate used in the printing process will also affect the size of the bar code that can be accurately printed.

If possible, when using flexographic printing, the bars should run parallel to the press web direction. If the bars are required to be perpendicular to the press direction, try to avoid distorting the symbol for the plate roll circumference. This lack of distortion will alter the overall width of the symbol, but will provide dimensional integrity. When using either silk screen or rotogravure printing processes, the symbol must be aligned parallel to the cell structure on the screen or gravure plate cylinder to provide the smoothest bar edge possible.





Printing on demand

Printing bar codes on demand is necessary when including variable information, such as expiry dates, in GS1-128 bar codes for traded units. Some users will want to print bar coded labels on demand for some consumer units, especially when these items are not contained in pre-printed packaging. On demand printing techniques include direct thermal, thermal transfer, laser, ion deposition, ink jet and mechanical matrix.

First of all check that your label design software is compatible with the printer hardware you are planning to use, and that the printer resolution is adequate for the bar codes you are printing. In general this means that your printer must have a resolution of at least 8 dots per mm (approximately 200 dots per inch) as it has to use a whole number of dots to make up the width of the narrowest bars required.

An 8 dpmm printer will be able to print bar codes whose X-dimensions are 0.25 mm, 0.375 mm, and 0.50 mm. A 12 dpmm printer (approximately 300 dots per inch) will be able to print bars with X-dimensions of 0.25 mm, 0.333 mm, 0.416 mm, 0.50 mm and so on.



All on demand printers, whether they are direct thermal, thermal transfer, dot matrix, ink jet or laser, will print better bar codes with well defined edges if they are printing the bar codes in picket fence orientation. This means that the bars go in the same direction as the substrate when it passes through the printer.

Printing in picket fence orientation means that the width of the bar code can be no wider than the print head.

If it is necessary to print a bar code which would be wider than the print head, then it must be printed in ladder orientation. This means that any failure in the print head elements will cause white lines to appear across the bar code. These faults in effect reduce the height of the bar code and make it more difficult to scan.

Matching the label stock with the technique being used is also important, as poor quality paper can create dust which can cause the print heads to burn out sooner than expected. It is also necessary to match thermal transfer ribbons to the equipment being used, and ensure that the correct pressures are being used with the print heads. The incorrect choice of ribbon and paper may be workable, but the machinery is likely to require much higher maintenance costs and require much more frequent servicing. It is highly recommended to use validated combinations of ribbons and labels, and to use verification equipment to check the print quality.

Direct thermal printing may be appropriate for some products, and the correct label stock must be sourced. Bear in mind that these labels remain heat sensitive and may be inappropriate if goods are kept in direct sunlight or if the labels are heated in any subsequent process.

Appendix 5



Printing GS1-128 bar codes

These bar codes are often printed on demand, so the operator of the equipment needs to be aware of certain requirements.

Function 1

GS1-128 symbols are a subset of Code 128 and they require a special symbol character (a pattern of three bars and three spaces) called Function 1 to be used as part of the start pattern. If the Function 1 character is not correctly included as part of the start pattern the symbol will not meet the requirements of the GS1 System.



Enlarged section of first part of a GS1-128 bar code showing the Function 1 character in blue.

Choosing the correct character set

There is a choice of character sets to help users minimise the space taken up by these bar codes. Use character set C to print pairs of digits using one symbol character (a pattern of three bars and three spaces) rather than two symbol characters whenever possible. If single letters or numbers are required use character sets B or A.

Concatenation

Concatenation is an effective means for encoding several element strings in a single bar code and should be used to save label space and optimise scanning operations.

The element strings may appear in any order in a GS1-128 bar code.

The best practice is to put data of fixed length before any variable data to minimise the length of the bar code. If a variable length field is followed by another element string, it must be terminated by the Function 1 character. When a variable length field appears at the end of a GS1-128 bar code it does not need to be terminated by the Function 1 character.

If the SSCC is used, it must always appear in the lowest bar code on the label. The SSCC can be alone

or concatenated with other data in the same bar code. Concatenation cannot be used with the SSCC on standard A6 labels because the bar code would be too wide for the label.

Choosing the correct size

GS1-128 bar codes can vary in size according to how well they can be printed. The maximum width for the X-dimension (the width of the narrowest bars and spaces) is 1.016 mm and the minimum X-dimension is 0.495 mm when these bar codes are used on trade item groupings.

Users must choose an X-dimension that can be reproduced by their on demand printing equipment. The X-dimension must be a multiple of the size of the smallest line that can be printed, and if an 8 dpmm (200 dpi) printer is used, the X-dimensions can be 0.50 mm, 0.625 mm, 0.75 mm, 0.875 mm and 1.00 mm.

If using labels, an X-dimension of 0.50 mm will be acceptable, provided the printed bar codes, when verified, meet the minimum grade required.

If printing these GS1-128 bar codes directly onto fibreboard outercases an X-dimension of 1.00 mm is recommended, but verifiers must still be used to check that the bar codes meet the minimum grade required. Further information about verification is provided in section 9.





Height of bars

Whichever X-dimension is chosen, the height of the bars must be at least 32 mm.

Keeping adequate Quiet Zones

The Quiet Zones on each side of a symbol which has an X-dimension of 1 mm are 10 mm. The Quiet Zone is always equal to 10 times the X-dimension, but when the X-dimension is 0.50 mm it is recommended that the Quiet Zones are at least 7 mm on each side.

When are brackets required around the application identifiers?

Brackets are used around each application identifier (AI) in the data printed below the bar code. This makes it easier for people to read the AI and the data it denotes. The brackets are not encoded into the GS1-128 bar code itself.

Determining the length of a GS1-128 bar code

GS1-128 bar codes will vary in length depending on the types of information they carry so it is important to check that the intended length of the bar code, with the necessary Quiet Zones to the left and right, is no longer than 165.1 mm. Each symbol character (except the stop character) has a width of 11 mm if an X-dimension of 1 mm is chosen, and each symbol must include four symbol characters to begin and complete the bar code.

For example, how long will a GS1-128 bar code be that includes a GTIN and an expiry date? The data required in the bar code is all numeric so character set C will be chosen.

The data required in the bar code will be as follows:

010501234567890017060606.

The bar code begins with Start C and Function 1 characters and ends with a symbol check character and the stop character. The 24 numbers required in the bar code will be shown by 12 symbol characters in this character set, so the complete symbol will be 16 symbol characters in length.

The width of the bar code (if an X-dimension of 1 mm is chosen) will be:

(16 x 11) mm + 2 mm extra for the stop character + 20 mm for the two Quiet Zones

$$176 + 2 + 20 = 198 \text{ mm.}$$

This measurement exceeds the maximum allowed length so the X-dimension must be reduced. If an X-dimension of 0.50 mm is chosen the bar code will be half this length, 99 mm.

If an X-dimension of 0.625 mm is chosen the length will be 123.75 mm, and with an X-dimension of 0.75 mm, the length will be 148.5 mm.





Choosing the correct application identifiers

When providing extra information on a traded unit, most users will encode the GTIN for the product with information such as an expiry date. The GTIN on the item must be preceded by the AI 01, and the extra information denoted by using the AIs as explained in the GS1 General Specifications. The most commonly used AIs and their field lengths are given below.

When labelling pallets, the GS1 logistics label must be used. All the data shown on the label must refer to the contents of the whole pallet. The SSCC is the only compulsory element, and will be the only reference used on pallets of mixed product.

For pallets with uniform contents, any of the AIs listed below can be used. Please remember that you cannot use AIs 01 and 02 together.



AI 01 must only be used when the pallet is also a traded unit, ie. it is ordered and invoiced as a single item. In all other cases, use the AIs 02 and 37 to describe the contents of the pallet.

This is not an exhaustive list of all the application identifiers that can be used on traded units or on pallets. Please consult the GS1 General Specifications to find a complete listing of all the AIs.

AI	Description	Format	
00	Serial Shipping Container Code	Fixed length, 18 digits	Has to be used on all GS1 logistics labels
01	Identification of trade item	Fixed length, 14 digits	
02	Identification of the content of a logistics unit	Fixed length, 14 digits	Must not be used with AI 01 identification of a trade item
10	Batch or lot number	Variable length, up to 20 alphanumeric characters	Each AI must only be used once on each label; mixed batches and mixed product variants cannot be identified using the AI standards
15	Best Before Date	YYMMDD, fixed length, 6 digits	When used the pallet must contain products with the same best before date
16	Sell By Date	YYMMDD, fixed length, 6 digits	Indicates the date specified by the manufacturer as the last date the retailer is to offer the product for sale to the consumer
17	Use By or Expiry Date	YYMMDD, fixed length, 6 digits	When the pallet must contain products with the same expiry date
20	Product Variant	Fixed, 2 digits	
21	Serial Number	Variable length, up to 20 alphanumeric characters	Cannot be used to identify more than one item
37	Count of Trade Items contained in a Logistic Unit	Variable length, up to 8 digits	Must not be used with AI 01
3102	Net weight in kilos two decimal places	Fixed length, 6 digits	Must only be used with a variable measure GTIN-14



Appendix 6



Symbol show through

When a traded unit is bar coded it must not be possible to read any of the bar codes on the consumer units inside the packaging. If the bar codes can be read, there is a good chance that one of these will be read instead of the correct one on the outside of the case. This problem is called symbol show through.

When show through takes place it makes it very difficult to use an automatic scanning system reliably as the wrong item may be scanned. This means incorrect data capture and the wrong price being charged at the point of sale.



This is a particular problem for cash and carry retailers who sell both traded and consumer units to their customers. They cannot choose to read only, say ITF-14 and GS1-128 bar codes, at their points of sale as they do need to be able to read EAN-13 symbols on consumer units as well.

This problem also affects grocery and other retailers who sell large multipacks which are also traded units. Care must be taken to avoid packaging consumer units so that their bar codes are visible in their entirety. Packaging waste regulations encourage many manufacturers to make more use of shrink wrapping, and using patterned or obscuring film may be considered as a means of making consumer unit bar codes unreadable.

If the consumer units are rectangular in plan it may be possible to ensure that all the bar codes on the individual items face inside the outer case, but this will not be feasible with round products such as cans and bottles. When consumer units are packed on cardboard trays and then shrink wrapped, show through can be avoided by printing the bar codes in ladder orientation and towards the bottom of each consumer unit. This will mean that the edges of the tray will obscure part of the consumer units' bar codes and make them unscannable.

Appendix 7



How X-dimensions and magnification factors compare

Each bar code has a modular design, in that the different widths of bar and space (and Quiet Zones) are all multiples of the width of a module. The module width is the same as that of the narrowest bar or space, and this is also known as the X-dimension.

When EAN-8, EAN-13, UPC-A and UPC-E bar codes are at their nominal size, the X-dimension is 0.33mm. This means that the widths of the bars and spaces of these particular symbols should be one, two, three or four times 0.33 mm. When any one of these bar codes is made larger or smaller, the symbol is kept in proportion, so a wider bar code is also taller.

If the size of ITF-14 or GS1-128 bar codes is varied, only their width changes, as the height of the bars must be 32 mm for use on traded units or pallet labels. This means that referring to the size of these bar codes in terms of their X-dimension is more appropriate, as only one aspect of the symbol is changing.

The relationship between X-dimension and nominal size is not the same for all bar codes. In the GS1 system there is one for the EAN/UPC bar codes, and another for the ITF-14 and GS1-128 bar codes. These two relationships are shown in the tables to the right:

X-dimensions and magnifications for EAN/UPC bar codes

X-dimension	Magnification
0.25 mm	75.75%
0.264 mm	80%
0.33 mm	100%
0.495 mm	150%
0.66 mm	200%

X-dimensions and magnifications for ITF-14 and GS1-128 bar codes

X-dimension	Magnification
0.495 mm	48.7%
0.635 mm	62.5%
1.016 mm	100%

x- dimension explained

There are only four widths of black and white elements in EAN-8, EAN-13, UPC-A and UPC-E bar codes

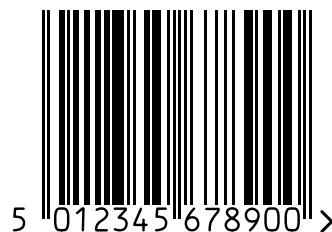
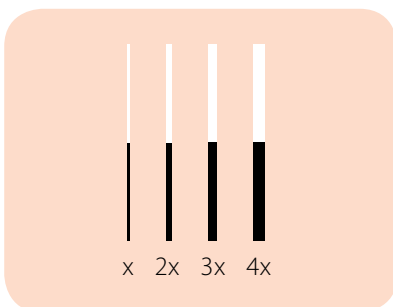

The width of the smallest bar or space is called the X-dimension; all other elements are multiples of this dimension.



Further information



This booklet only provides a summary of the GS1 specifications for the bar coding of goods that are handled in open trade. If the application of any of this advice is unclear, please contact the staff at GS1 UK for clarification.

The complete GS1 General Specifications are available free of charge via the GS1 UK website at www.gs1uk.org.

Further information and advice are also available from the bar code manager at each relevant retailer and wholesaler, as well as from the staff of GS1 UK. Initial calls to GS1 UK should be made via the membership services team on 0808 178 8799 or email info@gs1uk.org.

Information about ISO/IEC, CEN and ANSI standards is available from the British Standards Institution, 389 Chiswick High Road, London, W4 4AL, website: www.bsi-global.com, or telephone 020 8996 9001.

Disclaimer

The objective of this document is to provide GS1 UK members with user friendly and simple bar coding best practice guidelines. The document is not exhaustive and does not replace the GS1 General Specifications which remain the standard reference document.

Whilst every effort has been made to ensure that the contents of this document are correct, GS1 UK, and any other party involved in the creation of the document hereby state that the document is provided without warranty, either expressed or implied, of accuracy or fitness for purpose, and hereby disclaim any liability, direct or indirect, for damages or loss relating to the use of the document. The document may be modified from time to time, subject to developments in technology, changes to the standards, or new legal requirements.

These guidelines for best practice have the support of many GS1 UK members including the following companies and organisations:

Axicon Auto ID
Booker Cash & Carry
H J Heinz Company
IGD
Iceland Foods
ISIS Integration
Nestlé UK
Mars
Sainsbury's Supermarkets
Tesco Stores
Unilever
Waitrose
William Morrison Supermarkets



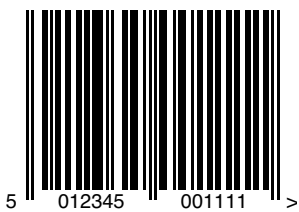

Staple Court,
11 Staple Inn Buildings
London WC1V 7QH
T +44 (0)20 7092 3500
F +44 (0)20 7681 2290
E info@gs1uk.org
Service Team (Freephone) 0808 178 8799
www.gs1uk.org