

SPECTRO Series

▶ SPECTRO-3-FIO-UV-SL

- Big working range: typ. 1 mm ... 500 mm (depends on the fiber optics used and attachment optics)
- Various UV fiber optics (reflected light operation) and attachment optics available
- Up to 3 colors (max. 64 colors in GROUP mode) can be taught
- UV LED, 375 nm, modulated (AC-/DC-operation or OFF for luminous objects can be switched)
- Detection of different luminescent colors
- Insensitive to outside light (in AC-operation)
- Brightness correction can be activated (STAT/DYN)
- Scan frequency max. 85 kHz (in DC- or OFF-operation)
- Switching frequency typ. 60 kHz
- TEACH via PC or teach button
- Various evaluation algorithms can be activated
- "BEST HIT" mode ("human color assessment")
- Switching state indication by means of 2 yellow LED
- Parameterizable via Windows® software, scope function
- Temperature compensated
- Averaging can be activated (from 1 up to over 32000 values)
- 3-color filter detector (true color detector: "human color perception")
- Compact aluminum housing



Design

Product name:

SPECTRO-3-FIO-UV-SL

(incl. Windows® PC software SPECTRO3-SL-Scope)

Accessories: (p. 8-11)

Fiber optics
Attachment optics
Fiber optics mounting

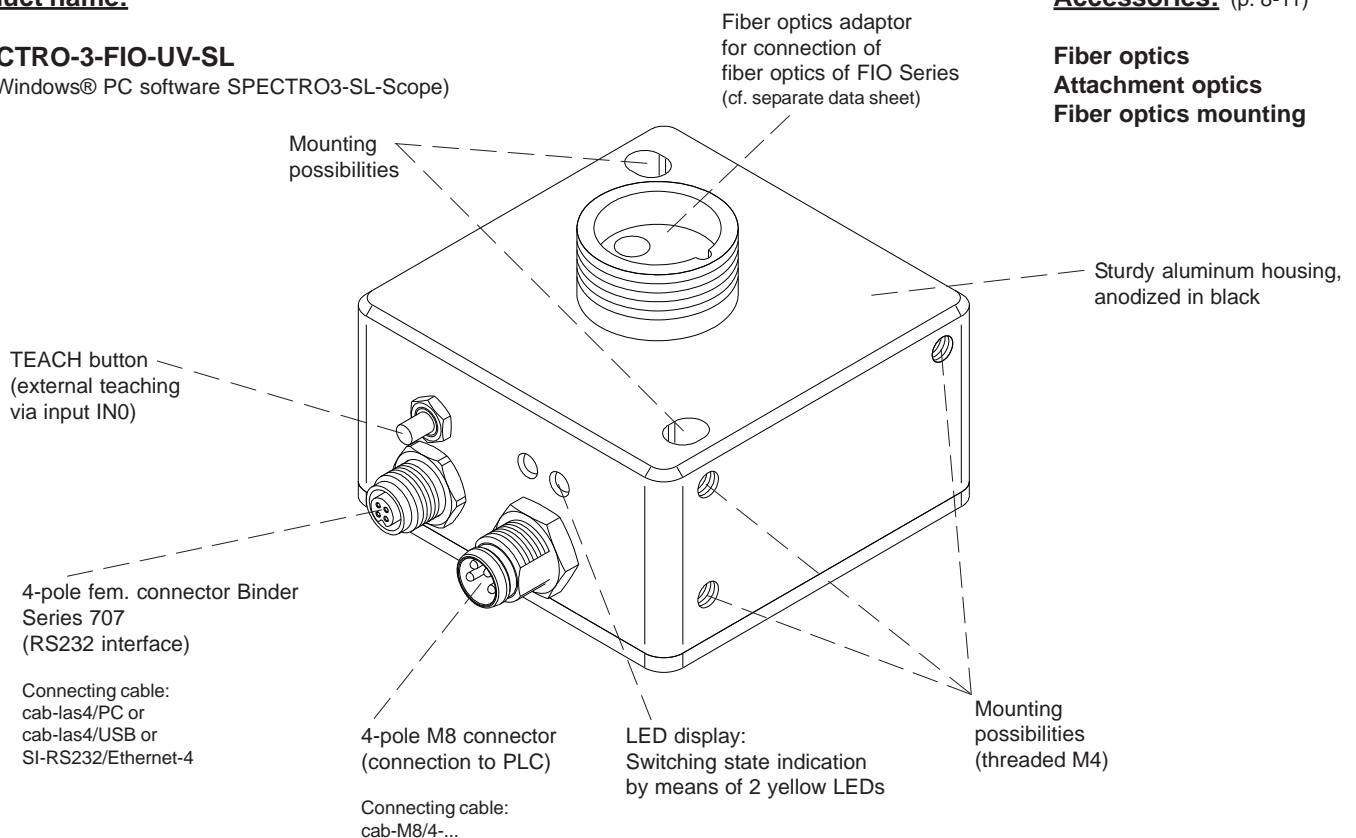



Technical Data

Model	SPECTRO-3-FIO-UV-SL
Voltage supply	+24VDC (± 10%), reverse polarity protected, overcurrent protected
Current consumption	< 160 mA
Max. switching current	100 mA, short circuit proof
Switching state indication	2 yellow LED visualize the physical state of the outputs OUT0 and OUT1
Trigger input IN0 (1x)	teach button at the housing
Outputs digital (2x)	OUT0 and OUT1 (Pin 2 and Pin 4): digital (0V/+24V), npn/pnp-able (bright-/dark-switching, can be switched)
Interface	RS232
Pulse lengthening	0 ... 100 ms, adjustable via PC software
Averaging	max. 32768 values, adjustable via PC software
Scan frequency	LED operation, can be switched via PC software: AC operation: max. 28 kHz (depends on parameterization) DC and OFF operation: max. 85 kHz (depends on parameterization)
Switching frequency	typ. 60 kHz
Transmitter (light source)	UV-LED, 375 nm
Transmitter control	can be switched via PC software: AC operation (LED MODE-AC), DC operation (LED MODE-DC), OFF operation (LED MODE-OFF)
Object distance (measuring range)	with reflected light fiber optics: typ. 1 mm ... 500 mm (depends on fiber optics and attachment optics) with transmitted light fiber optics: typ. 10 mm ... 500 mm (depends on fiber optics and attachment optics)
Receiver	3-color filter detector (TRUE COLOR detector, "human color perception"), color filter curves acc. to CIE 1931
Receiver gain setting	8 steps (AMP1 ... AMP8), adjustable via PC software
Ambient light	max. 5000 Lux
Size of light spot	circular: typ. Ø 1.5 mm ... Ø 3 mm or rectangular: typ. 3 mm x 0.5 mm ... 6 mm x 1 mm depends on fiber optics and attachment optics (cf. catalog FIO series)
Reproducibility	in the X, Y color range each 1 digit at 12-bit A/D conversion
Temperature drift X,Y	$\Delta X/\Delta T$; $\Delta Y/\Delta T$ typ. 0,2 digits/°C (< 0,01% / °C)
Color difference	$\Delta E \geq 0,5$
Color space	X Y INT siM (Lab)
Teach button	external teaching of up to 3 colors (max. 64 in GROUP mode) via teach button at sensor housing (IN0) via the corresponding evaluation mode, adjustable via PC software
Color memory capacity	non-volatile EEPROM with parameter sets for max. 3 colors (max. 64 colors in GROUP mode)
Housing dimensions	LxWxH approx. 50 mm x 50 mm x 36 mm (incl. fiber optics adapter M18x1, without flange connectors)
Housing material	aluminum, anodized in black
Enclosure rating	IP64
Connecting cables	to PLC: cab-M8/4-g-... or cab-M8/4-w-... to PC/RS232 interface: cab-las4/PC or cab-las4/PC-w to PC/USB interface: cab-las4/USB or cab-las4/USB-w to PC/Ethernet interface: SI-RS232/Ethernet-4
Type of connector	connection to PLC: 4-pole M8-connector, connection to PC: 4-pole fem. connector (Binder 707)
Operating temp. range	-20°C ... +55°C
Storage temperature range	-20°C ... +85°C
EMC test acc. to	DIN EN 60947-5-2



Connector Assignment

**Connection to PLC:
4-pole M8 connector**

Pin:	Color:	Assignment:
1	brown	+Ub (+24VDC ± 10%)
2	white	OUT0
3	blue	GND (0V)
4	black	OUT1

Connecting cable:
cab-M8/4-g-(length) or
cab-M8/4-w-(length) (angle type 90°)
(standard length 2m)

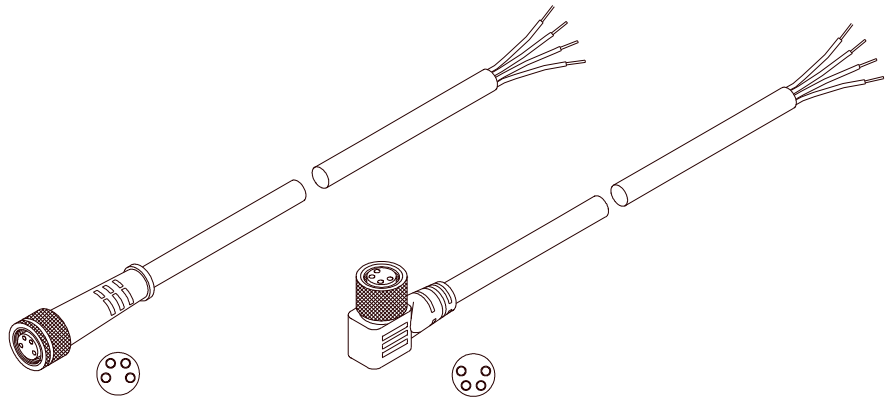

cab-M8/4-g-2-...
(max. length 5m, outer jacket: PUR)

cab-M8/4-w-...
(max. length 5m, outer jacket: PU)

**Connection to PC:
4-pole fem. connector Binder Series 707**

Pin:	Assignment:
1	+24VDC (+Ub, OUT)
2	GND (0V)
3	RxD
4	TxD

Connection via RS232 interface at the PC:
Connecting cable:
cab-las4/PC-(length)
cab-las4/PC-w-(length) (angle type 90°)
(standard length 2m)

alternative:
Connection via USB interface at the PC:
Connecting cable (incl. driver software):
cab-las4/USB-(length)
cab-las4/USB-w-(length) (angle type 90°)
(standard length 2m)

alternative:
Connection to local network via Ethernet bus:
Adapter (based on Lantronix XPortModul):
SI-RS232/Ethernet-4-(length)
(standard length 2m)

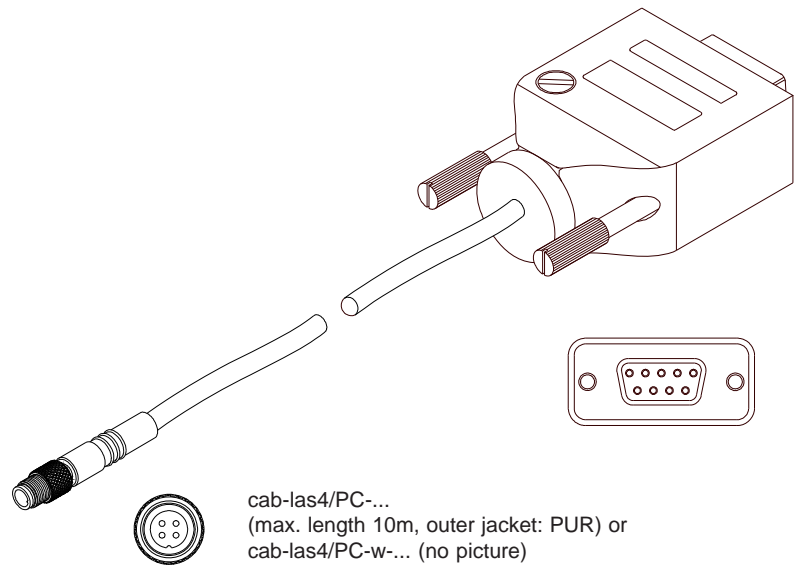

cab-las4/PC-...
(max. length 10m, outer jacket: PUR) or
cab-las4/PC-w-... (no picture)
(max. length 5m, outer jacket: PUR)

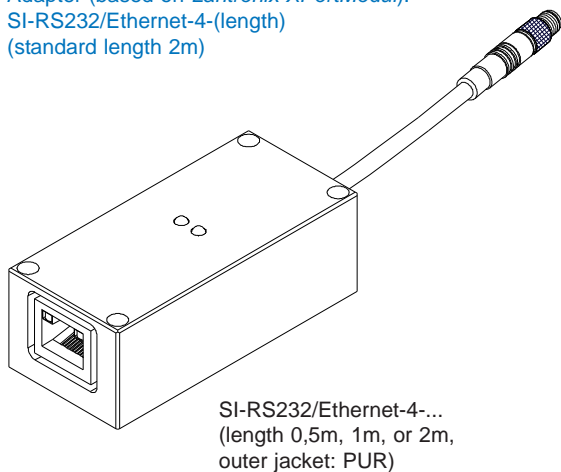

SI-RS232/Ethernet-4-...
(length 0,5m, 1m, or 2m,
outer jacket: PUR)

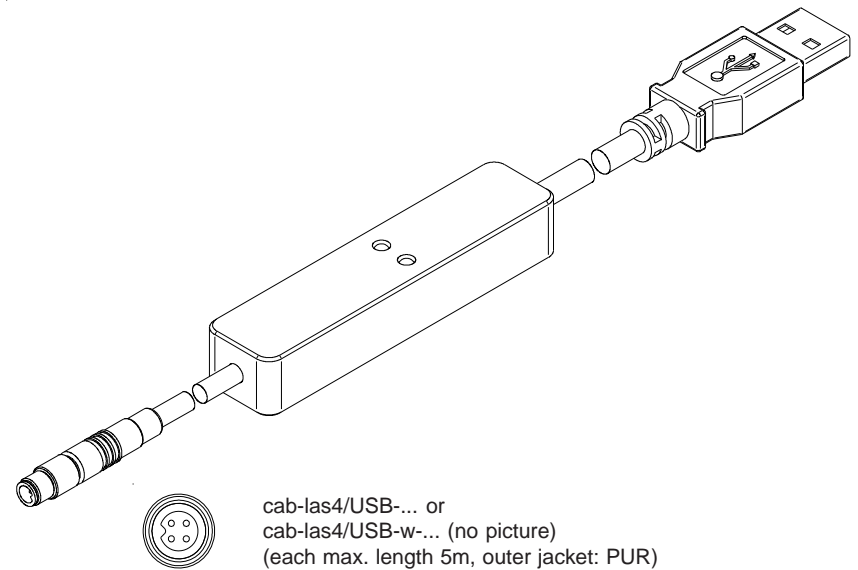

cab-las4/USB-... or
cab-las4/USB-w-... (no picture)
(each max. length 5m, outer jacket: PUR)



Measuring Principle

Measuring principle of color sensors of SPECTRO-3-...-SL Series:

The color sensor SPECTRO-3-...-SL provides highly flexible signal acquisition. For example, the sensor can be operated in alternating-light mode (AC mode), which makes the sensor insensitive to extraneous light. It also can be set to constant-light mode (DC mode), which makes the sensor extremely fast. An OFF function turns off the integrated light source at the sensor and changes to DC operation. The sensor then can detect so-called "self-luminous objects". With the stepless adjustment of the integrated light source as well as the selectable gain of the receiver signal and an INTEGRAL function the sensor can be set to almost any surface or any "self-luminous object". When the integrated light source of the SPECTRO-3-...-SL color sensor is activated, the sensor detects the radiation that is diffusely reflected from the object.

As a light source the SPECTRO-3-...-SL color sensor uses a white-light LED with adjustable transmitter power. An integrated 3-fold receiver for the red, green, and blue content of the light that is reflected from the object, or the light that is emitted by a "self-luminous object", is used as a receiver.

As a light source the SPECTRO-3-...-UV-SL color sensor uses a UV-LED (375 nm) with adjustable transmitter power to excite the luminescent marking. An integrated 3-fold receiver for the red, green, and blue content of the visible light that is emitted by the luminescent marking is used as a receiver. A special feature here is that the gain of the receiver can be set in 8 steps. This makes it possible to optimally adjust the sensor to almost any luminescent colorant that can be excited in the long-wave UV range.

The SPECTRO-3-...-SL color sensor can be "taught" up to 3 colors. For each of these taught colors it is possible to set tolerances. In "X Y INT - 2D" or "s i M - 2D" mode these tolerances form a color cylinder in space. In "X Y INT - 3D" or "s i M - 3D" mode the tolerances form a color sphere in space. Color evaluation according to "s i M - 2D" is based on the lab calculation method. All modes can be used in combination with several operating modes such as "FIRST HIT" and "BEST HIT". Raw data are represented with 12 bit resolution.

As a special feature the sensor can be taught two completely independent parameter sets. Input IN0 (push button at the sensor housing) can then be used to tell the sensor which parameter set it should work with.

Color detection either operates continuously or is started through an external PLC trigger signal.

The respective detected color either is provided as a binary code at the 2 digital outputs or can be sent directly to the outputs, if only up to 2 colors are to be detected. Through input IN0 (push button at the sensor housing) the color sensor can be taught up to 3 colors (max. 64 colors in group mode). For this purpose the corresponding evaluation mode must be set with the software.

Parameters and measurement values can be exchanged between a PC and the SPECTRO-3-...-SL color sensor through the serial RS232 interface. All the parameters for color detection also can be saved to the non-volatile EEPROM of the SPECTRO-3-...-SL color sensor through this serial RS232 interface. When parameterisation is finished, the color sensor continues to operate with the current parameters in STAND-ALONE mode without a PC.

The sensors of the SPECTRO-3-...-SL series can be calibrated (white-light balancing). Balancing can be performed to any white surface. A ColorChecker™ table with 24 color fields is available as an alternative. White-light balancing or calibration can be performed to one of the white, grey, or black fields.

The UV color sensors SPECTRO-3-...-UV-SL also can be calibrated. Analogous to white-light balancing with color sensors, balancing of the SPECTRO-3-...-UV-SL could be performed to any luminescent color marking.



LED Display

LED Display:

The two LEDs visualize the physical state of the outputs OUT0 und OUT1.

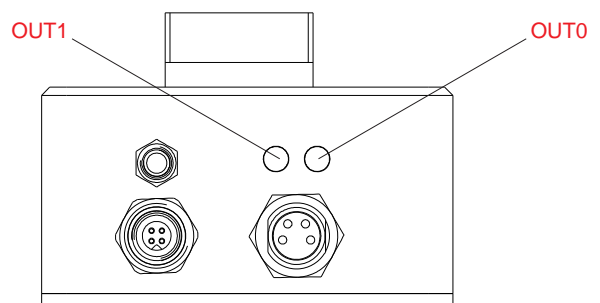

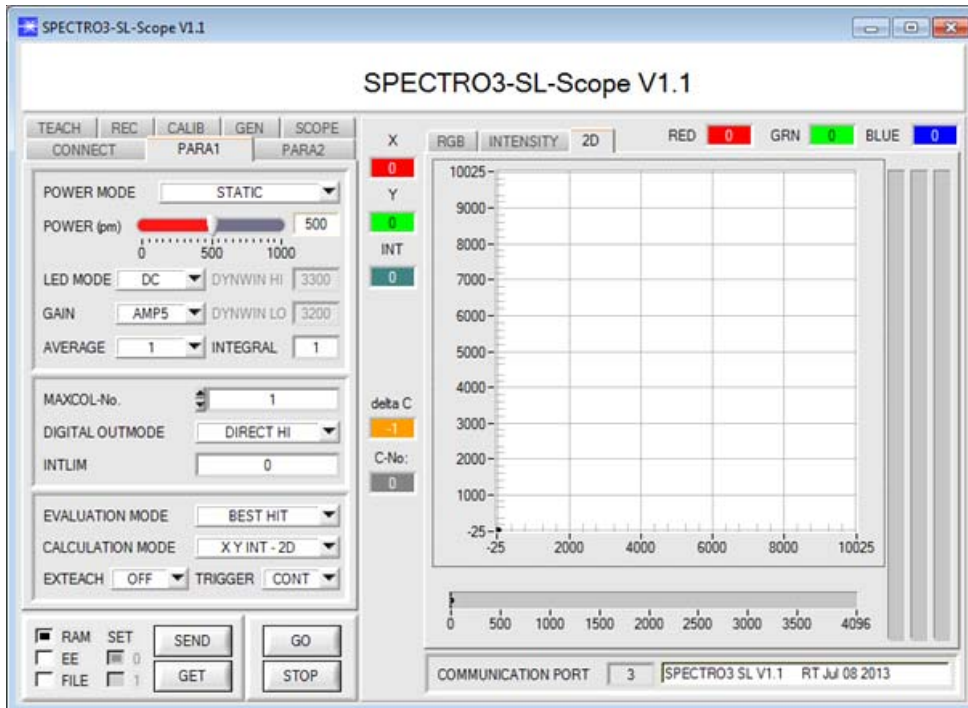

Windows® user interface:

The PC software facilitates the parameterization, the diagnosis, and the adjustment of the sensor system (oscilloscope function). Moreover, the software features a data recorder function that allows the automatic recording of recorded data and the saving of those at the hard disk of the PC.

Parameters and measurement values can be exchanged between PC and sensor either through RS232 or Ethernet (using an Ethernet adaptor, e.g. SI-RS232/Ethernet-4-...). Through the interface all the parameters can be stored in the non-volatile EEPROM of the sensor.

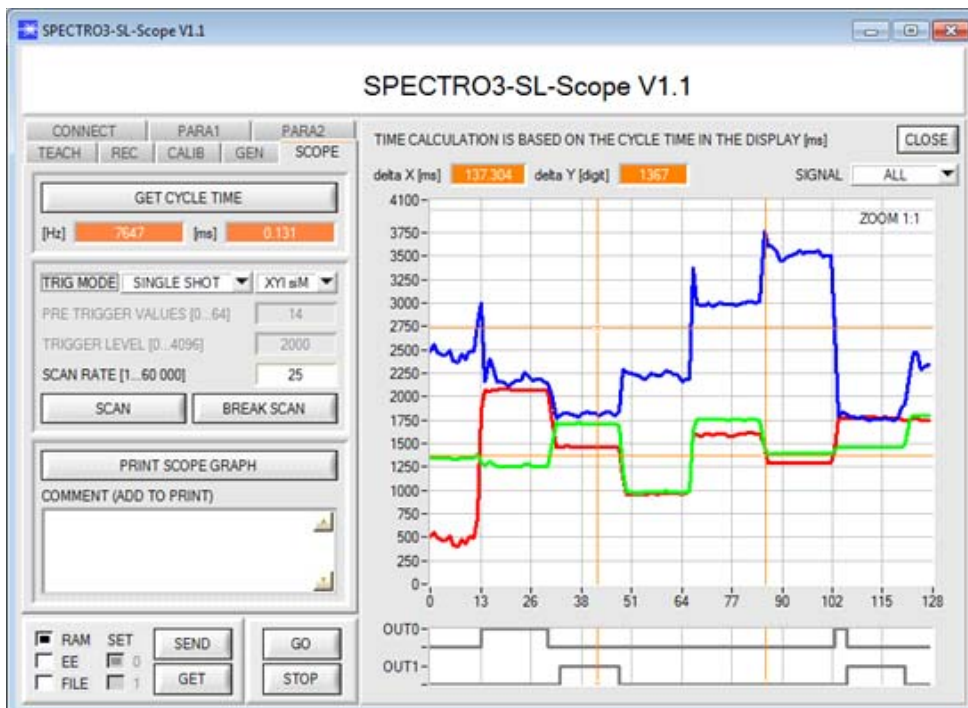
Under Windows® representation of the color value on a PC in numeric form and in a color chart, and representation of RGB values in a time chart. In addition the current RGB values are displayed as a bar chart.



The SCOPE tab visualises an oscilloscope.

Software update from SPECTRO3-SL-Scope V1.0 to V1.1:

The Teach Table was extended to 64 color vectors. The SPECTRO-3-SL color sensor only has 2 outputs. It is therefore possible to output a maximum of 3 colors in binary code. However, if the group mode is activated with **COLOR GROUPS = ON**, 64 colours can be learned, which can then be assigned to a maximum of 3 groups (0,1,2).

If **TRIGGER = PARA** is used, 64 color vectors can additionally be saved as **SET 1**. Input IN0 is used to switch between parameter and color vector sets.



Firmware Update

Firmware update by means of the software „FirmwareLoader“:



The software „Firmware Loader“ allows the user to perform an automatic firmware update. The update will be carried out through the RS232 interface.

An initialisation file (xxx.ini) and a firmware file (xxx.elf.S) are required for performing a firmware update. These files can be obtained from your supplier. In some cases an additional firmware file for the program memory (xxx.elf.p.S) is also needed, and this file will be automatically provided together with the other two files.



UV Fiber Optics

Field of use:

Optical fibers offer solutions for difficult tasks in optoelectronics. They can be used universally and allow flexible applications.

Advantages:

- Highest quality
- Selection from different fiber types
- Thermal stability
- Great variety of available standard sensor heads
- Various attachment optics available
- Special designs

Available UV fiber optics for connection:

- R-S-A1.1-(1.5)-1200-22°-UV
- R-S-A2.0-(2.5)-1200-22°-UV
- R-S-A3.0-(3.0)-1200-22°-UV
- R-S-R1.1-(3x0.5)-1200-22°-UV
- R-S-R2.1-(6x1)-1200-22°-UV



Characteristics:

Light-conducting glass fibers are optical components that allow the transmission of light through any curved path based on the principle of total reflection. The individual fiber is composed of high-break core glass and low-break cladding glass. The light beams entering the core glass within the critical angle are guided through the fiber by way of reflection at the core/cladding contact surfaces (step index fiber). The highly flexible optical fibers are made of bundled individual glass fibers. The ends are each glued into a sensor head and a connector. The faces are optically polished. For protection against mechanical, chemical, or thermal destruction the optical fibers are provided with a corresponding protective sheath.

Order Code:

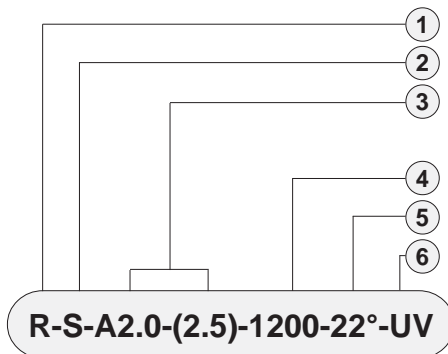

R-S-A2.0-(2.5)-1200-22°-UV

Order code for optical fiber

(For detailed description of the various types of fiber optics please cf. catalog „FIO Series“)

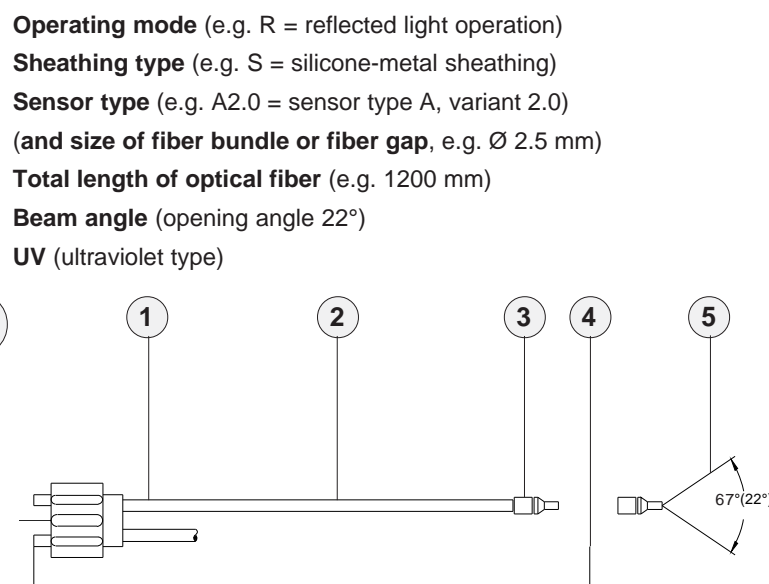

Dimensions of adapter

Attachment optics (e.g. focus lens, reflex optics, prism optics)

Fiber optics for reflex light operation

Fiber optics for transmitted light operation

Mounting hints

- cf. catalog FIO Series
- cf. catalog FIO Series
- cf. catalog FIO Series
- cf. catalog FIO Series
- cf. catalog FIO Series



Optical Frontends

Overview: Optical frontends for reflected light UV fiber optics



KL-3 (A2.0)
KL-4 (A1.1)
KL-5 (R1.1)
KL-8 (R2.1)
KL-9 (A3.0)



KL-M8-A1.1



KL-M12-A1.1
KL-M12-A2.0
KL-M12-A3.0
KL-M12-R1.1



KL-M12-XL-A1.1
KL-M12-XL-A2.0
KL-M12-XL-R1.1



KL-M18-A1.1
KL-M18-A2.0
KL-M18-A3.0
KL-M18-R1.1
KL-M18-R2.1



KL-M18-XL-A1.1
KL-M18-XL-A2.0
KL-M18-XL-A3.0
KL-M18-XL-R1.1
KL-M18-XL-R2.1



KL-M34-A1.1
KL-M34-A2.0
KL-M34-A3.0
KL-M34-R1.1
KL-M34-R2.1



KL-M34-XL-A1.1
KL-M34-XL-A2.0
KL-M34-XL-A3.0
KL-M34-XL-R1.1
KL-M34-XL-R2.1



KL-M34/62-A1.1
KL-M34/62-A2.0
KL-M34/62-A3.0
KL-M34/62-R1.1
KL-M34/62-R2.1



Optical Frontends

Optical frontends for UV fiber optics (22°-UV) or UV fiber optics in Y-shape (22°/67°-UV, used with external UV light source):

Part number:	Suitable for UV fiber optics type: (R = reflected light)	Characteristics:
KL-3	R-S-A2.0-(2.5)-1200-22°-UV	Working distance typ. 10 mm ... 20 mm
	R-S-A2.0-(2.5)-1200-Y-22°/67°-UV	Working distance typ. 10 mm ... 20 mm
KL-4	R-S-A1.1-(1.5)-1200-22°-UV	Working distance typ. 10 mm ... 15 mm
	R-S-A1.1-(1.5)-1200-Y-22°/67°-UV	Working distance typ. 10 mm ... 15 mm
KL-5	R-S-R1.1-(3x0.5)-1200-22°-UV	Working distance typ. 8 mm ... 20 mm
	R-S-R1.1-(3x0.5)-1200-Y-22°/67°-UV	Working distance typ. 8 mm ... 20 mm
KL-8	R-S-R2.1-(6x1)-1200-22°-UV	Working distance typ. 8 mm ... 25 mm
	R-S-R2.1-(6x1)-1200-Y-22°/67°-UV	Working distance typ. 8 mm ... 25 mm
KL-9	R-S-A3.0-(3.0)-1200-22°-UV	Working distance typ. 8 mm ... 25 mm
	R-S-A3.0-(3.0)-1200-Y-22°/67°-UV	Working distance typ. 8 mm ... 25 mm
KL-M8-A1.1	R-S-A1.1-(1.5)-1200-22°-UV	Working distance typ. 8 mm ... 20 mm
	R-S-A1.1-(1.5)-1200-Y-22°/67°-UV	Working distance typ. 8 mm ... 20 mm
KL-M12-A1.1	R-S-A1.1-(1.5)-1200-22°-UV	Working distance typ. 8 mm ... 20 mm
	R-S-A1.1-(1.5)-1200-Y-22°/67°-UV	Working distance typ. 8 mm ... 20 mm
KL-M12-A2.0	R-S-A2.0-(2.5)-1200-22°-UV	Working distance typ. 8 mm ... 20 mm
	R-S-A2.0-(2.5)-1200-Y-22°/67°-UV	Working distance typ. 8 mm ... 20 mm
KL-M12-A3.0	R-S-A3.0-(3.0)-1200-22°-UV	Working distance typ. 8 mm ... 20 mm
	R-S-A3.0-(3.0)-1200-Y-22°/67°-UV	Working distance typ. 8 mm ... 20 mm
KL-M12-R1.1	R-S-R1.1-(3x0.5)-1200-22°-UV	Working distance typ. 8 mm ... 20 mm
	R-S-R1.1-(3x0.5)-1200-Y-22°/67°-UV	Working distance typ. 8 mm ... 20 mm
KL-M12-XL-A1.1	R-S-A1.1-(1.5)-1200-22°-UV	Working distance typ. 30 mm ... 200 mm
	R-S-A1.1-(1.5)-1200-Y-22°/67°-UV	Working distance typ. 30 mm ... 200 mm
KL-M12-XL-A2.0	R-S-A2.0-(2.5)-1200-22°-UV	Working distance typ. 30 mm ... 200 mm
	R-S-A2.0-(2.5)-1200-Y-22°/67°-UV	Working distance typ. 30 mm ... 200 mm
KL-M12-XL-R1.1	R-S-R1.1-(3x0.5)-1200-22°-UV	Working distance typ. 30 mm ... 200 mm
	R-S-R1.1-(3x0.5)-1200-Y-22°/67°-UV	Working distance typ. 30 mm ... 200 mm
KL-M18-A1.1	R-S-A1.1-(1.5)-1200-22°-UV	Working distance typ. 10 mm ... 60 mm
	R-S-A1.1-(1.5)-1200-Y-22°/67°-UV	Working distance typ. 10 mm ... 60 mm
KL-M18-A2.0	R-S-A2.0-(2.5)-1200-22°-UV	Working distance typ. 10 mm ... 80 mm
	R-S-A2.0-(2.5)-1200-Y-22°/67°-UV	Working distance typ. 10 mm ... 80 mm
KL-M18-A3.0	R-S-A3.0-(3.0)-1200-22°-UV	Working distance typ. 10 mm ... 80 mm
	R-S-A3.0-(3.0)-1200-Y-22°/67°-UV	Working distance typ. 10 mm ... 80 mm
KL-M18-R1.1	R-S-R1.1-(3x0.5)-1200-22°-UV	Working distance typ. 10 mm ... 60 mm
	R-S-R1.1-(3x0.5)-1200-Y-22°/67°-UV	Working distance typ. 10 mm ... 60 mm
KL-M18-R2.1	R-S-R2.1-(6x1)-1200-22°-UV	Working distance typ. 10 mm ... 80 mm
	R-S-R2.1-(6x1)-1200-Y-22°/67°-UV	Working distance typ. 10 mm ... 80 mm



Optical Frontends

Optical frontends for UV fiber optics (22°-UV) or UV fiber optics in Y-shape (22°/67°-UV, used with external UV light source):

Part number:	Suitable for UV fiber optics type: (R = reflected light)	Characteristics:
KL-M18-XL-A1.1	R-S-A1.1-(1.5)-1200-22°-UV R-S-A1.1-(1.5)-1200-Y-22°/67°-UV	Working distance typ. 50 mm ... 300 mm Working distance typ. 50 mm ... 300 mm
KL-M18-XL-A2.0	R-S-A2.0-(2.5)-1200-22°-UV R-S-A2.0-(2.5)-1200-Y-22°/67°-UV	Working distance typ. 50 mm ... 300 mm Working distance typ. 50 mm ... 300 mm
KL-M18-XL-A3.0	R-S-A3.0-(3.0)-1200-22°-UV R-S-A3.0-(3.0)-1200-Y-22°/67°-UV	Working distance typ. 50 mm ... 300 mm Working distance typ. 50 mm ... 300 mm
KL-M18-XL-R1.1	R-S-R1.1-(3x0.5)-1200-22°-UV R-S-R1.1-(3x0.5)-1200-Y-22°/67°-UV	Working distance typ. 50 mm ... 300 mm Working distance typ. 50 mm ... 300 mm
KL-M18-XL-R2.1	R-S-R2.1-(6x1)-1200-22°-UV R-S-R2.1-(6x1)-1200-Y-22°/67°-UV	Working distance typ. 50 mm ... 300 mm Working distance typ. 50 mm ... 300 mm
KL-M34-A1.1	R-S-A1.1-(1.5)-1200-22°-UV R-S-A1.1-(1.5)-1200-Y-22°/67°-UV	Working distance typ. 50 mm ... 200 mm Working distance typ. 50 mm ... 200 mm
KL-M34-A2.0	R-S-A2.0-(2.5)-1200-22°-UV R-S-A2.0-(2.5)-1200-Y-22°/67°-UV	Working distance typ. 50 mm ... 250 mm Working distance typ. 50 mm ... 250 mm
KL-M34-A3.0	R-S-A3.0-(3.0)-1200-22°-UV R-S-A3.0-(3.0)-1200-Y-22°/67°-UV	Working distance typ. 50 mm ... 300 mm Working distance typ. 50 mm ... 300 mm
KL-M34-R1.1	R-S-R1.1-(3x0.5)-1200-22°-UV R-S-R1.1-(3x0.5)-1200-Y-22°/67°-UV	Working distance typ. 50 mm ... 200 mm Working distance typ. 50 mm ... 200 mm
KL-M34-R2.1	R-S-R2.1-(6x1)-1200-22°-UV R-S-R2.1-(6x1)-1200-Y-22°/67°-UV	Working distance typ. 50 mm ... 300 mm Working distance typ. 50 mm ... 300 mm
KL-M34-XL-A1.1	R-S-A1.1-(1.5)-1200-22°-UV R-S-A1.1-(1.5)-1200-Y-22°/67°-UV	Working distance typ. 50 mm ... 400 mm Working distance typ. 50 mm ... 400 mm
KL-M34-XL-A2.0	R-S-A2.0-(2.5)-1200-22°-UV R-S-A2.0-(2.5)-1200-Y-22°/67°-UV	Working distance typ. 50 mm ... 400 mm Working distance typ. 50 mm ... 400 mm
KL-M34-XL-A3.0	R-S-A3.0-(3.0)-1200-22°-UV R-S-A3.0-(3.0)-1200-Y-22°/67°-UV	Working distance typ. 50 mm ... 400 mm Working distance typ. 50 mm ... 400 mm
KL-M34-XL-R1.1	R-S-R1.1-(3x0.5)-1200-22°-UV R-S-R1.1-(3x0.5)-1200-Y-22°/67°-UV	Working distance typ. 50 mm ... 400 mm Working distance typ. 50 mm ... 400 mm
KL-M34-XL-R2.1	R-S-R2.1-(6x1)-1200-22°-UV R-S-R2.1-(6x1)-1200-Y-22°/67°-UV	Working distance typ. 50 mm ... 400 mm Working distance typ. 50 mm ... 400 mm
KL-M34/62-A1.1	R-S-A1.1-(1.5)-1200-22°-UV R-S-A1.1-(1.5)-1200-Y-22°/67°-UV	Working distance typ. 80 mm ... 200 mm Working distance typ. 80 mm ... 200 mm
KL-M34/62-A2.0	R-S-A2.0-(2.5)-1200-22°-UV R-S-A2.0-(2.5)-1200-Y-22°/67°-UV	Working distance typ. 80 mm ... 200 mm Working distance typ. 80 mm ... 200 mm
KL-M34/62-A3.0	R-S-A3.0-(3.0)-1200-22°-UV R-S-A3.0-(3.0)-1200-Y-22°/67°-UV	Working distance typ. 80 mm ... 200 mm Working distance typ. 80 mm ... 200 mm
KL-M34/62-R1.1	R-S-R1.1-(3x0.5)-1200-22°-UV R-S-R1.1-(3x0.5)-1200-Y-22°/67°-UV	Working distance typ. 80 mm ... 200 mm Working distance typ. 80 mm ... 200 mm
KL-M34/62-R2.1	R-S-R2.1-(6x1)-1200-22°-UV R-S-R2.1-(6x1)-1200-Y-22°/67°-UV	Working distance typ. 80 mm ... 200 mm Working distance typ. 80 mm ... 200 mm