

# SPECTRO Series

## ► SPECTRO-3-50-UV-JR

- Measuring range typ. 10 mm ... 100 mm
- Transmitter power of UV LED can be adjusted for excitation of luminescent marks
- Up to 31 colors can be stored
- RS232 interface (USB or Ethernet adapter is available)
- 8x UV LED, 385 nm, focused (AC-/DC-/PULSE-operation or OFF for luminous objects can be switched)
- Detection of different luminescent colors
- Insensitive to outside light (in AC- or PULSE-operation)
- Brightness correction can be activated (STAT/DYN)
- Scan frequency max. 35 kHz (in DC- or OFF-operation)
- Switching frequency typ. 40 kHz
- Several TEACH functions (via PC, PLC, or push button)
- Various evaluation algorithms can be activated
- "BEST HIT" mode ("human color assessment")
- Parameterizable via Windows® software, scope function
- Temperature compensated
- Averaging can be activated (from 1 up to over 32000 values)
- 3-color filter detector (true color detector: "human color perception")



## Aufbau

### Product name:

### SPECTRO-3-50-UV-JR

(incl. software SPECTRO3-Scope)

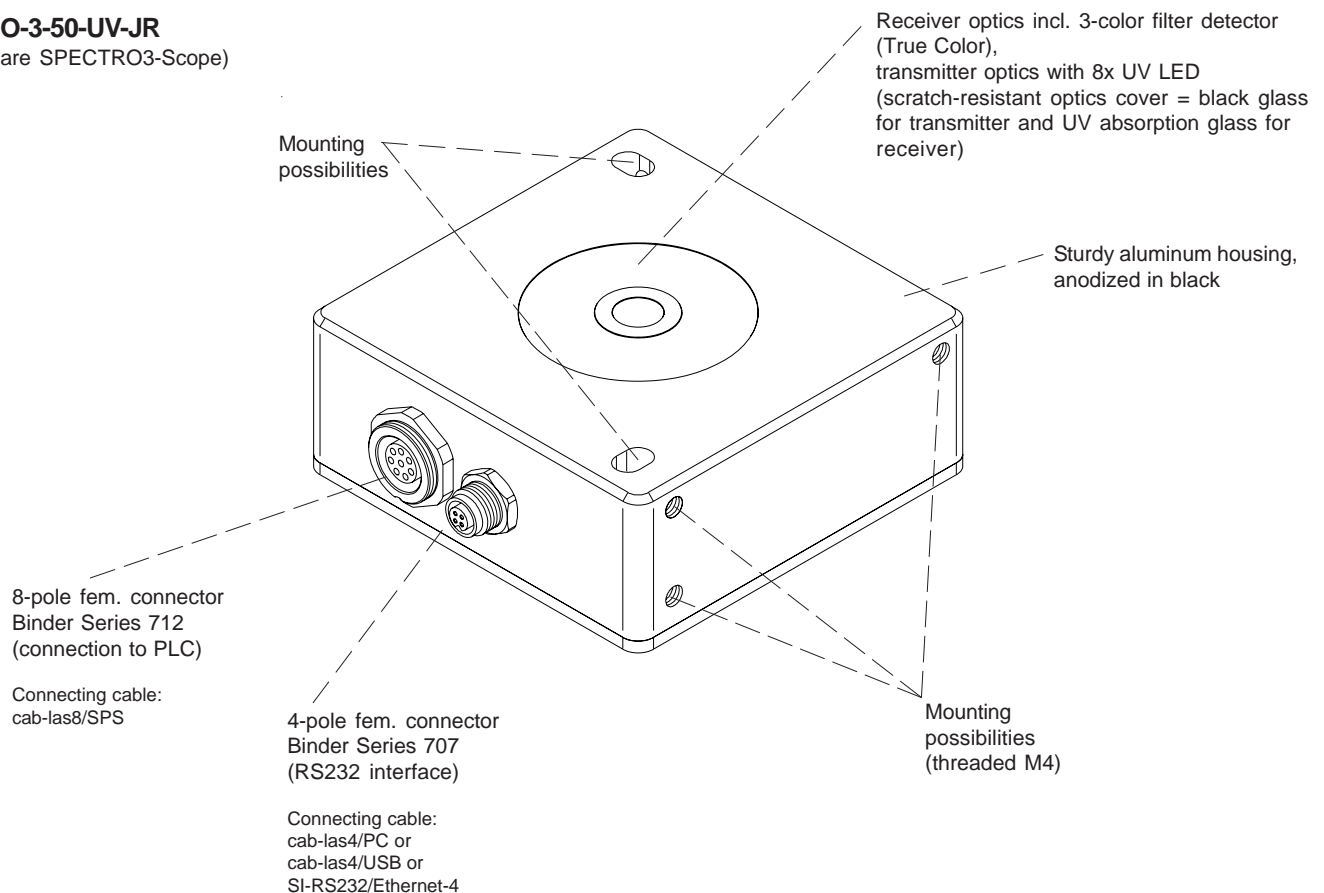



**Technical Data**

Model	SPECTRO-3-50-UV-JR
Voltage supply	+24VDC (± 10%), reverse polarity protected, overcurrent protected
Current consumption	< 220 mA
Max. switching current	100 mA, short circuit proof
Input digital (1x)	IN0 (Pin 3), digital (0V/+24V)
Outputs digital (5x)	OUT0 ... OUT4 (Pin 4 ... 8): digital (0V/+24V), npn/pnp-able (bright/dark-switching, can be switched)
Interface	RS232
Pulse lengthening	0 ... 100 ms, adjustable via PC software
Averaging	max. 32768 values, adjustable via PC software
Scan frequency	LED operation, can be switched via PC software: AC operation: max. 20 kHz (depends on parameterization) DC and OFF operation: max. 35 kHz (depends on parameterization) PULSE operation: max. 5 kHz (depends on parameterization)
Switching frequency	typ. 60 kHz
Transmitter (light source)	8x UV LED, 385 nm, focused
Transmitter control	can be switched via PC software: AC operation (LED MODE-AC), DC operation (LED MODE-DC), OFF operation (LED MODE-OFF)
Measuring range	typ. 10 mm ... 100 mm
Receiver	3-color filter detector (TRUE COLOR detector, "human color perception"), color filter curves acc. to CIE 1931
Receiver gain setting	8 steps (AMP1 ... AMP8), adjustable via PC software
Ambient light	max. 5000 Lux
Detection range (half intensity width)	typ. 10 mm (at a distance of 10 mm) typ. 17 mm (at a distance of 30 mm) typ. 27 mm (at a distance of 50 mm) typ. 33 mm (at a distance of 70 mm) typ. 40 mm (at a distance of 90 mm)
Reproducibility	in the X, Y color range each 1 digit at 12-bit A/D conversion
Temperature drift X,Y	$\Delta X/\Delta T$ ; $\Delta Y/\Delta T$ typ. 0,2 digits/°C (< 0,01% / °C)
Color difference	$\Delta E \geq 0,5$
Color space	X Y INT siM (Lab)
Color memory capacity	non-volatile EEPROM with parameter sets for max. 31 colors
Housing dimensions	LxWxH approx. 65 mm x 65 mm x 26 mm (without flange connectors)
Housing material	aluminum, anodized in black
Enclosure rating	IP64
Connecting cables	to PLC: cab-las8/SPS or cab-las8/SPS-w to PC/RS232 interface: cab-las4/PC or cab-las4/PC-w to PC/USB interface: cab-las4/USB or cab-las4/USB-w to PC/Ethernet interface: SI-RS232/Ethernet-4
Type of connector	connection to PLC: 8-pole fem. connector (Binder 712), connection to PC: 4-pole fem. connector (Binder 707)
Operating temp. range	-20°C ... +55°C
Storage temperature range	-20°C ... +85°C
EMC test acc. to	DIN EN 60947-5-2

Dimensions

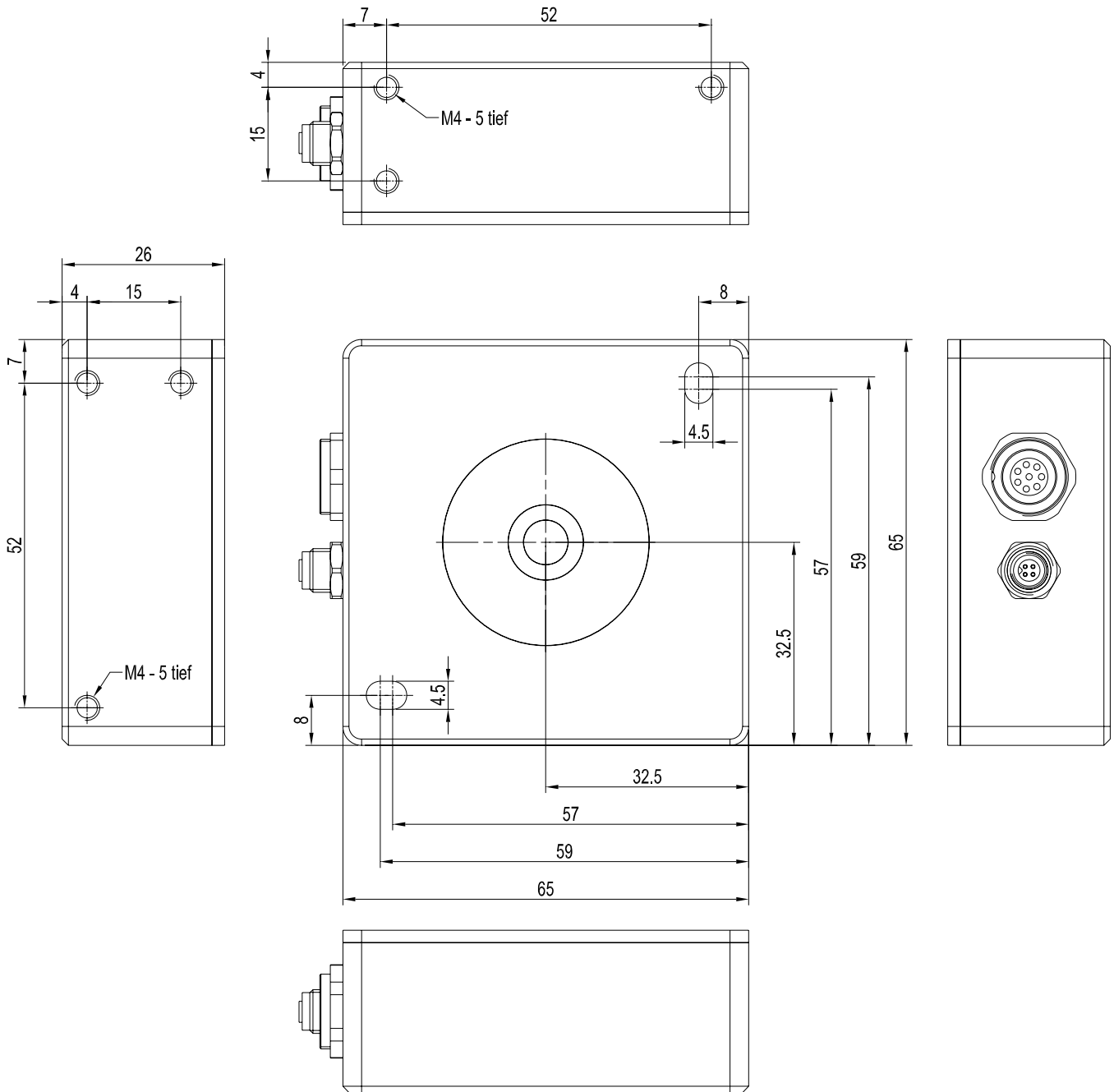

All dimensions in mm



**Connector Assignment**

**Connection to PLC:  
8-pole fem. connector Binder Series 712**

Pin:	Color:	Assignment:
1	white	GND (0V)
2	brown	+24VDC (±10%)
3	green	IN0
4	yellow	OUT0
5	grey	OUT1
6	pink	OUT2
7	blue	OUT3
8	red	OUT4

Connecting cable:  
cab-las8/SPS-(length)  
cab-las8/SPS-w-(length) (angle type, 90°)  
(standard length 2m)

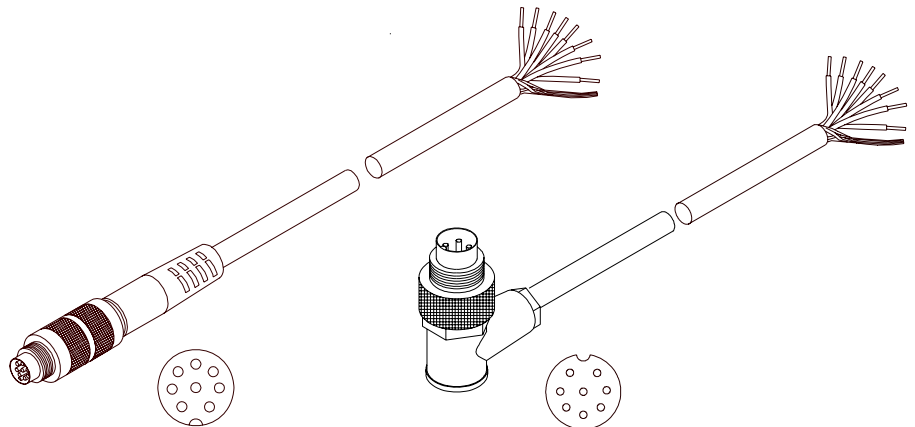

cab-las8/SPS-...  
(max. length 25m, outer jacket: PUR)

cab-las8/SPS-w-...  
(max. length 25m, outer jacket: PUR)

**Connection to PC:  
4-pole fem. connector Binder Series 707**

Pin:	Assignment:
1	+24VDC (+Ub, OUT)
2	GND (0V)
3	RxD
4	TxD

**Connection via RS232 interface at the PC:**  
Connecting cable:  
cab-las4/PC-(length)  
cab-las4/PC-w-(length) (angle type 90°)  
(standard length 2m)

**alternative:**  
**Connection via USB interface at the PC:**  
Connecting cable (incl. driver software):  
cab-las4/USB-(length)  
cab-las4/USB-w-(length) (angle type 90°)  
(standard length 2m)

**alternative:**  
**Connection to local network via Ethernet bus:**  
Adapter (based on Lantronix XPortModul):  
SI-RS232/Ethernet-4-(length)  
(standard length 2m)

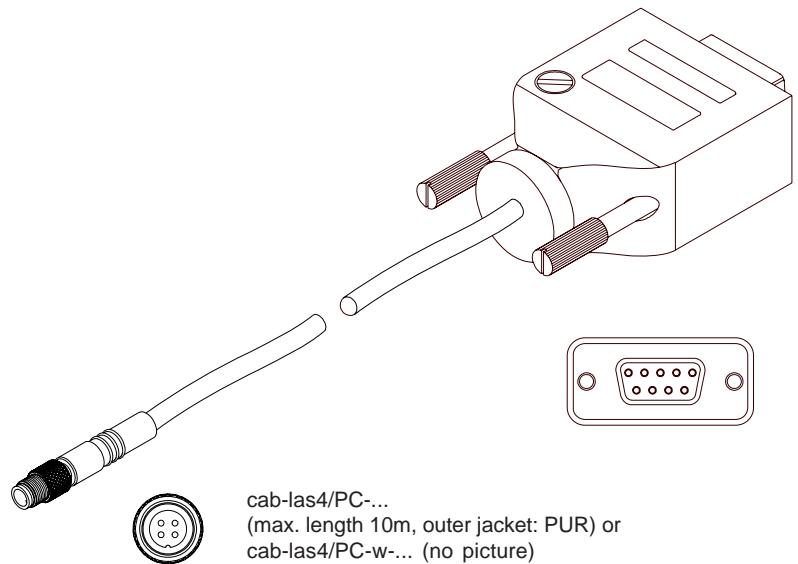

cab-las4/PC-...  
(max. length 10m, outer jacket: PUR) or  
cab-las4/PC-w-... (no picture)  
(max. length 5m, outer jacket: PUR)

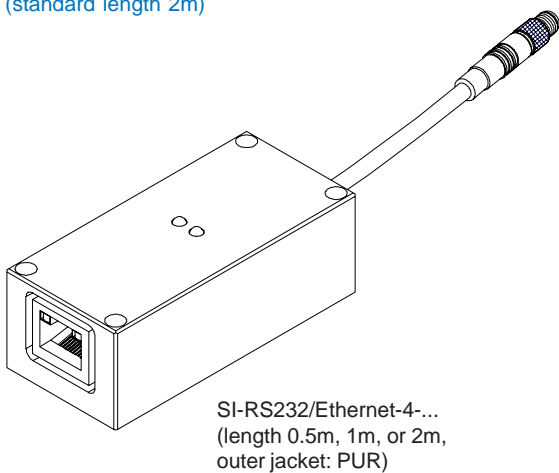

SI-RS232/Ethernet-4-...  
(length 0.5m, 1m, or 2m,  
outer jacket: PUR)

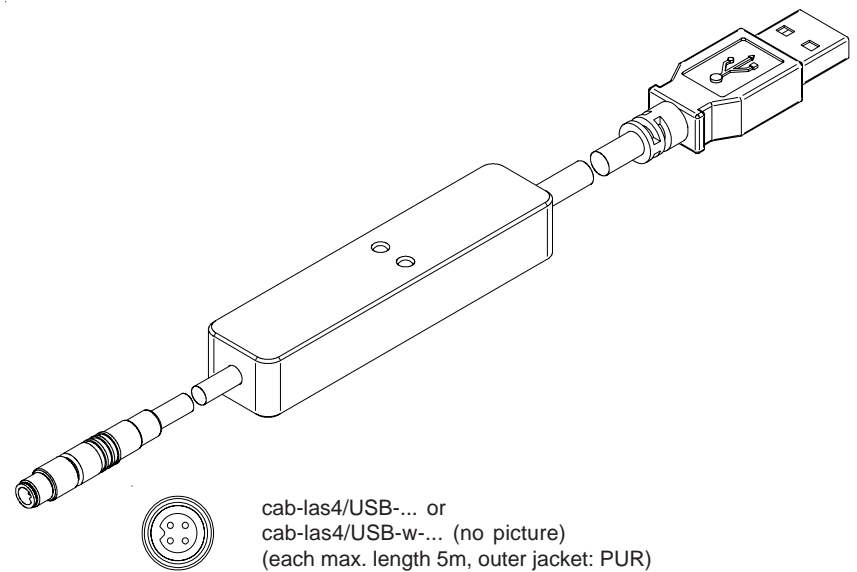

cab-las4/USB-... or  
cab-las4/USB-w-... (no picture)  
(each max. length 5m, outer jacket: PUR)

**Measuring Principle****Measuring principle of color sensors of SPECTRO-3-...-UV series:**

The SPECTRO-3 provides highly flexible signal acquisition. For example, the sensor can be operated in alternating-light mode (AC mode), which makes the sensor insensitive to extraneous light. It also can be set to constant-light mode (DC mode), which makes the sensor extremely fast and allows a scan-frequency of up to 35 kHz.

When the integrated light source of the SPECTRO-3-...-UV color sensor is activated, the sensor detects the radiation that is diffusely reflected from the object to be measured.

As a light source the SPECTRO-3-...-UV color sensor uses a UV-LED (385 nm, or 365 nm in case of using an external UV illumination unit SPECTRO-ELS-UV) with adjustable transmitter power to excite the luminescent marking. An integrated 3-fold receiver for the red, green, and blue content of the visible light that is emitted by the luminescent marking is used as a receiver. A special feature here is that the gain of the receiver can be set in 8 steps. This makes it possible to optimally adjust the sensor to almost any luminescent colorant that can be excited in the long-wave UV range (365 nm or 385 nm).

The SPECTRO-3 color sensor can be "taught" up to 31 colors. For each of these taught colors it is possible to set tolerances. In X/Y INT or s/i M mode these tolerances form a color cylinder in space. In X/Y/INT or s/i/M mode the tolerances form a color sphere in space. Color evaluation according to s/i M is based on the lab calculation method. All modes can be used in combination with several operating modes such as "FIRST HIT" and "BEST HIT". Raw data are represented with 12 bit resolution.

As a special feature the sensor can be taught two completely independent parameter sets. Input IN0 can then be used to tell the sensor which parameter set it should work with.

Color detection either operates continuously or is started through an external PLC trigger signal. The respective detected color either is provided as a binary code at the 5 digital outputs or can be sent directly to the outputs, if only up to 5 colors are to be detected. At the same time the detected color code is visualised by means of 5 LEDs at the housing of the SPECTRO-3. [Please note: Visualisation by means of LEDs not available with SPECTRO-3-...-JR types.]

With a TEACH button at the sensor housing the color sensor can be taught up to 31 colors. For this purpose the corresponding evaluation mode must be set with the software. The TEACH button is connected in parallel to the input IN0 (green wire at cable cab-las8/SPS). [Please note: TEACH button not available with SPECTRO-3-...-JR types.]

Parameters and measurement values can be exchanged between a PC and the SPECTRO-3 color sensor through the serial RS232 interface. All the parameters for color detection also can be saved to the non-volatile EEPROM of the SPECTRO-3 color sensor through this serial RS232 interface. When parameterisation is finished, the color sensor continues to operate with the current parameters in STAND-ALONE mode without a PC.

The sensors of the SPECTRO-3-...-UV series also can be calibrated. Analogous to white-light balancing with color sensors, balancing of the SPECTRO-3-...-UV could be performed to any luminescent color marking.

**Windows® user interface:**

The color sensor is parameterized under Windows® with the SPECTRO3-Scope software. The Windows® user interface facilitates the teach-in process at the color sensor and supports the operator in the task of adjustment and commissioning of the color sensor.

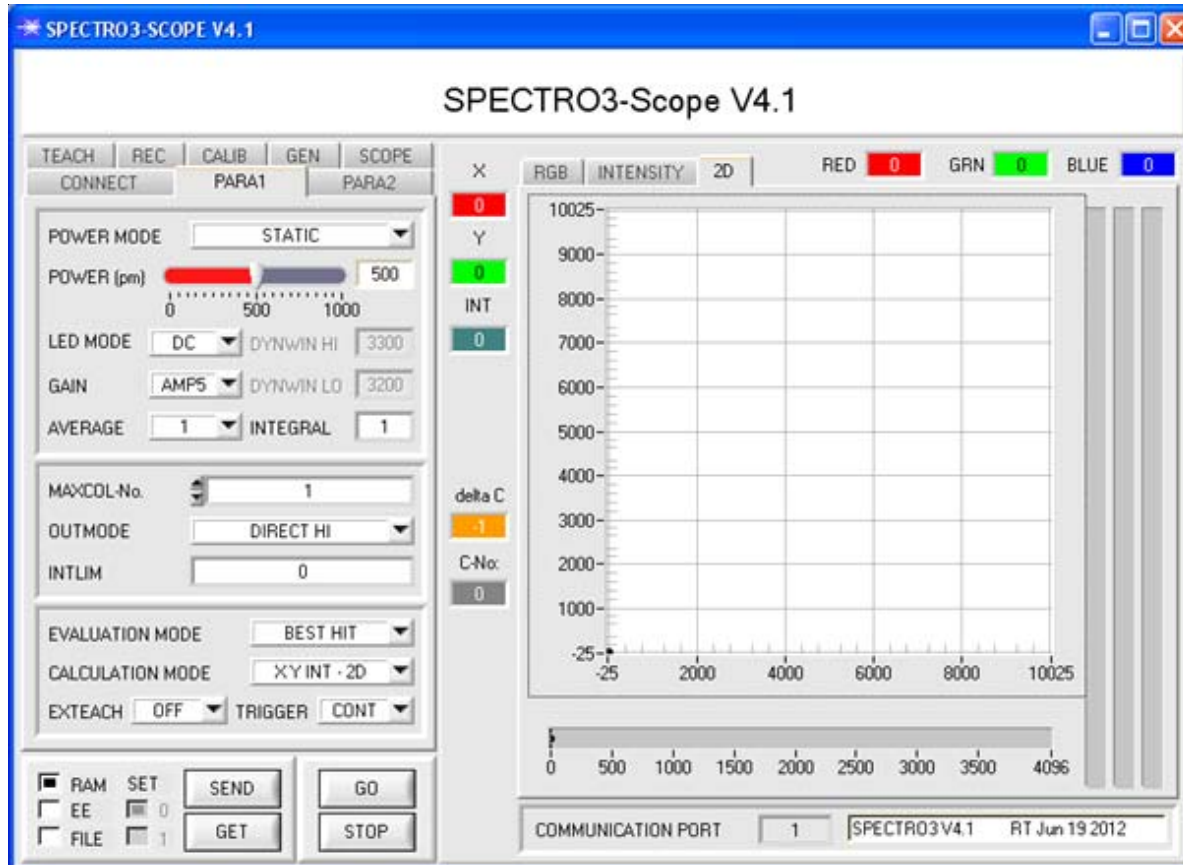

Under Windows® representation of the color value on a PC in numeric form and in a color chart, and representation of RGB values in a time chart. In addition the current RGB values are displayed as a bar chart.

The RS232 interface (tab PARA1 or PARA2) is used for setting parameters such as:

- POWER MODE: Light power of the LED
- LED MODE: Triggering of the internal light source
- GAIN: Used for setting the gain of the receiver
- AVERAGE: Averaging over a maximum of 32768 values
- INTEGRAL: This function field is used to set the number of scan values (measurement values) over which the raw signal measured at the receiver is summed up. This integral function allows the reliable detection even of extremely weak signals
- MAXCOL-No.: Number of colors to be checked
- OUTMODE: Triggering of the digital outputs
- INTLIM: Minimum intensity required for color evaluation
- EVALUATION MODE: Various evaluation modes to choose from (FIRST HIT, BEST HIT, MIN DIST, COL5)
- CALCULATION MODE: There are 2 methods of teaching a color. The CALCULATION MODE X/Y/INT (or s/i/M) uses a color sphere in space with radius TOL. Contrary to this, the CALCULATION MODE X/Y INT (or s/i M) uses a color cylinder in space with radius CTO or siTO and with height ITO or M.
- EXTEACH: In all the evaluation modes teaching of a color can be performed externally through IN0 or by means of the button at the sensor housing [Please note: TEACH button not available with SPECTRO-3-...-JR types.]
- TRIGGER: Continuous or external or self trigger



## Firmware Update

### Firmware update by means of the software „Program Loader“ or „Firmware Loader“:

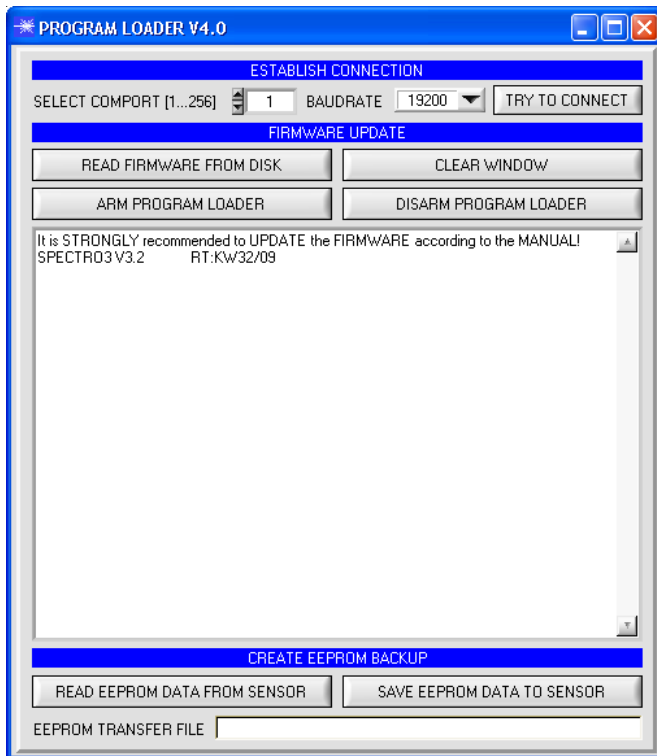

The software „Program Loader“ or „Firmware Loader“ allows the user to perform an automatic firmware update. The update will be carried out through the RS232 interface.

An initialisation file (xxx.ini) and a firmware file (xxx.elf.S) are required for performing a firmware update. These files can be obtained from your supplier. In some cases an additional firmware file for the program memory (xxx.elf.p.S) is also needed, and this file will be automatically provided together with the other two files.

A plausibility check is performed after the initialisation file has been loaded with the Program Loader. If the initialisation file was changed or damaged, it will not be possible to perform a firmware update.

When the plausibility check is successfully completed, the instructions contained in the initialisation file will be carried out step by step.

The complete memory contents of the micro-controller in the sensor will be deleted in a firmware update. This means that both the program in the program memory and the data in the data memory will be lost.

The new firmware automatically writes the correct data to the program memory again.

However, the parameter settings, temperature curves, linearization curves, etc. that are stored in the data memory (EEPROM) will be deleted.

With the Program Loader V4.0 software the data will be saved in the EEPROM, and can be written back again after successful firmware update. For this purpose the software creates an EEPROM backup file.

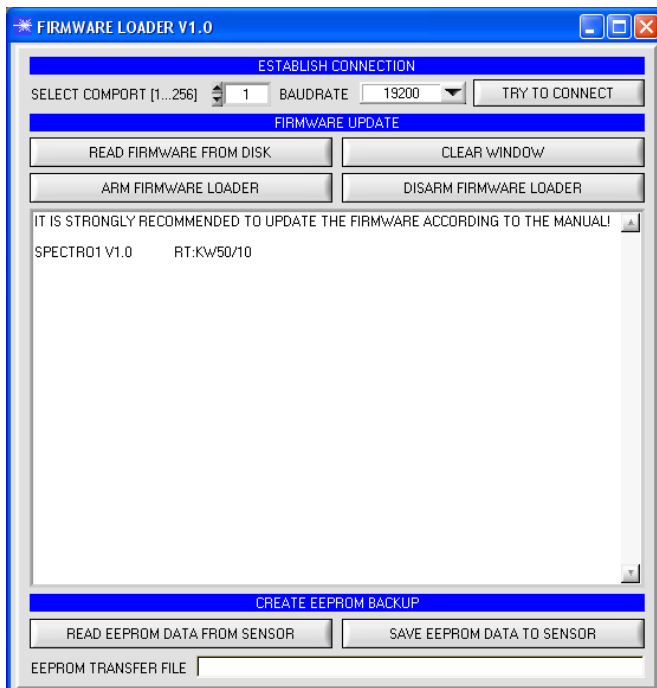





Diagrams

**Diagrams:** DETECTION RANGE (HALF INTENSITY WIDTH) and RELATIVE INTENSITY  
SPECTRO-3-50-UV-JR

**Detection range (half intensity width d)**  
SPECTRO-3-50-UV-JR:  
27 mm (typ.) at a working distance of 50 mm

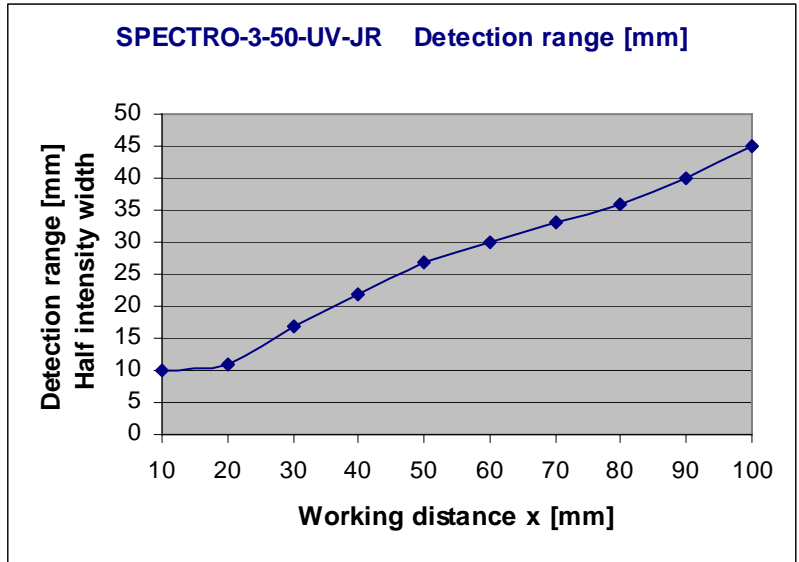

**Relative intensity**  
SPECTRO-3-50-UV-JR:  
100% at a working distance of 15 mm  
(INTENSITY 2062)

