

LWC Series

▶ LWC-80

Laser Wire Counting

- Insensitive to outside light (due to interference filter, modulated light)
- Visible laser spot (red light 670 nm)
- Parameterisable through integrated switch and RS232
- RS232 interface and Windows® user interface
- Automatic adjustment to product (laser power adjustment, dynamic dead time)
- Sensitivity setting through step switch (16 steps)
- EXTERN-TRIGGER mode can be activated via PC
- Counting of wires
- Counting of copies in compensating stackers
- Counting of copies during overhead conveying
- Reliable counting also of high-glossy and high-contrast copies



Design

Product name:

LWC-80

(incl. Windows® software SI-LWC-Scope)

Accessories:

TB-80 (attachment optics, cf. page 4)

INI-18 (approach switch, cf. page 4)

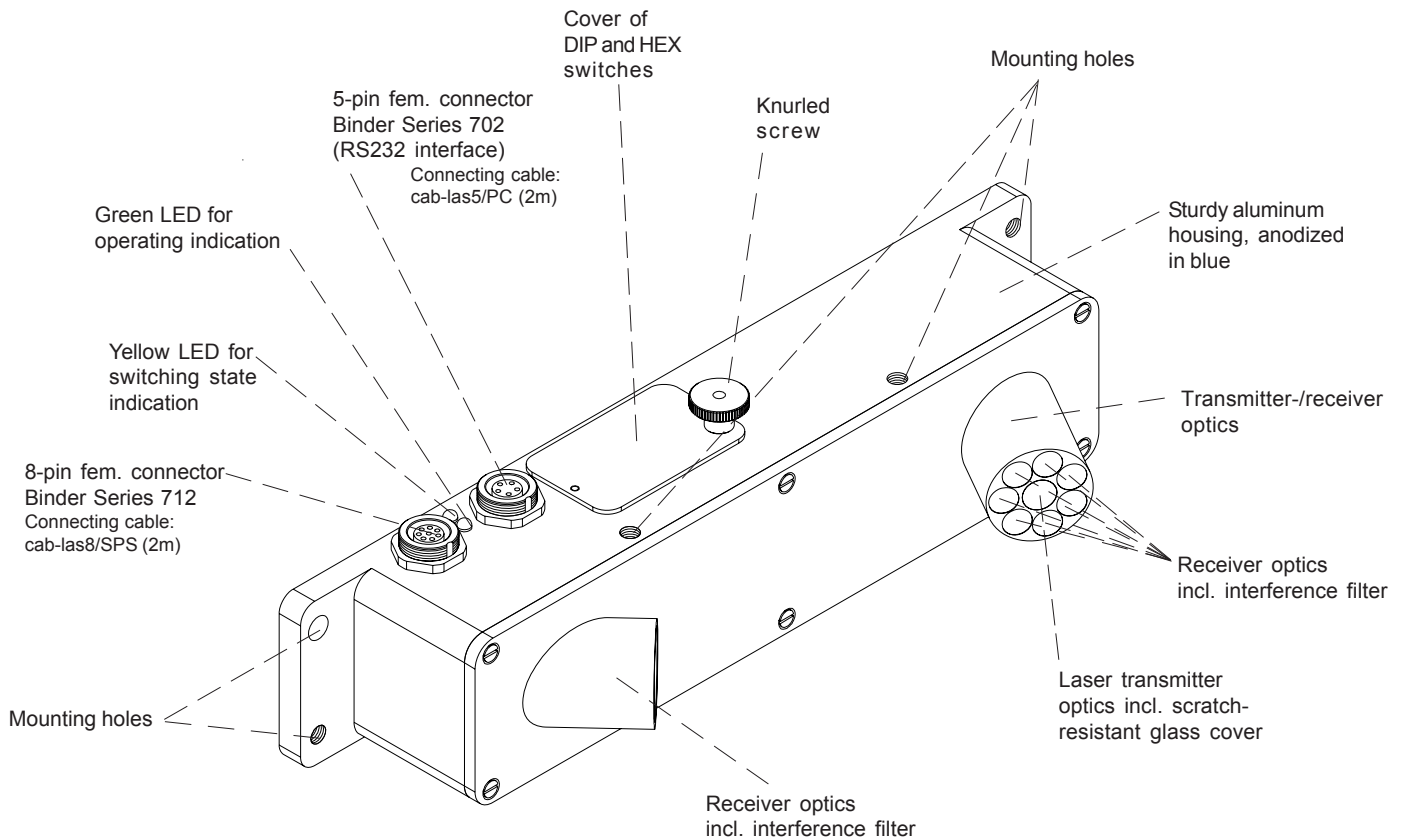



Technical Data

Model	LWC-80
Laser	Semi-conductor laser, 670 nm, AC operation, 1 mW max. opt. power, laser class 2 acc. to DIN EN 60825. The use of this laser sensor therefore requires no additional protective measures.
Optical filter	Interference filter and red light filter RG630
Digital output	pnp bright-switching/npn dark-switching or pnp dark-switching/npn bright-switching (OUT0 and OUT1), adjustable under Windows® on PC
Voltage supply	+12 VDC ... +30 VDC
Sensitivity setting	under Windows® on PC or by means of HEX coding switch (16 steps)
Laser power correction	adjustable under Windows® on PC
Current consumption	typ. 150 mA
Dead time	adjustable under Windows® on PC
Dead time mode	adjustable under Windows® on PC
Enclosure rating	IP54
Operating temperature range	-20°C ... +50°C
Storage temperature range	-20°C ... +85°C
Housing material	Aluminum, anodized in blue
Housing dimensions	approx. 205 mm x 40 mm x 40 mm
Type of connector	8-pin female connector type Binder Series 712 5-pin female connector type Binder Series 702
EMC test acc. to	IEC - 801 ...
Scan frequency	typ. 15 kHz (without averaging)
Switching state indication	Visualization by means of a yellow LED
Dynamic output (pulse lengthening)	adjustable under Windows® on PC
Max. switching current	100 mA, short-circuit protected
Interface	RS232, parameterizable under Windows®
Connecting cables	Connection to PC: cab-las5/PC (2m) Connection to PLC: cab-las8/SPS (2m)
Modulation frequency	typ. 100 kHz
Max. counting rate	typ. 500 000 edges/h
Min. height of object	typ. 0.1 mm
Output polarity	Bright-/dark-switching, adjustable under Windows® on PC
Working range	typ. 60 mm ... 100 mm

Dimensions

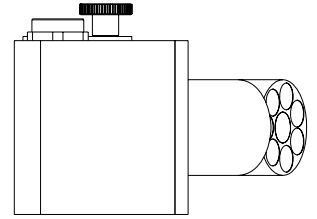
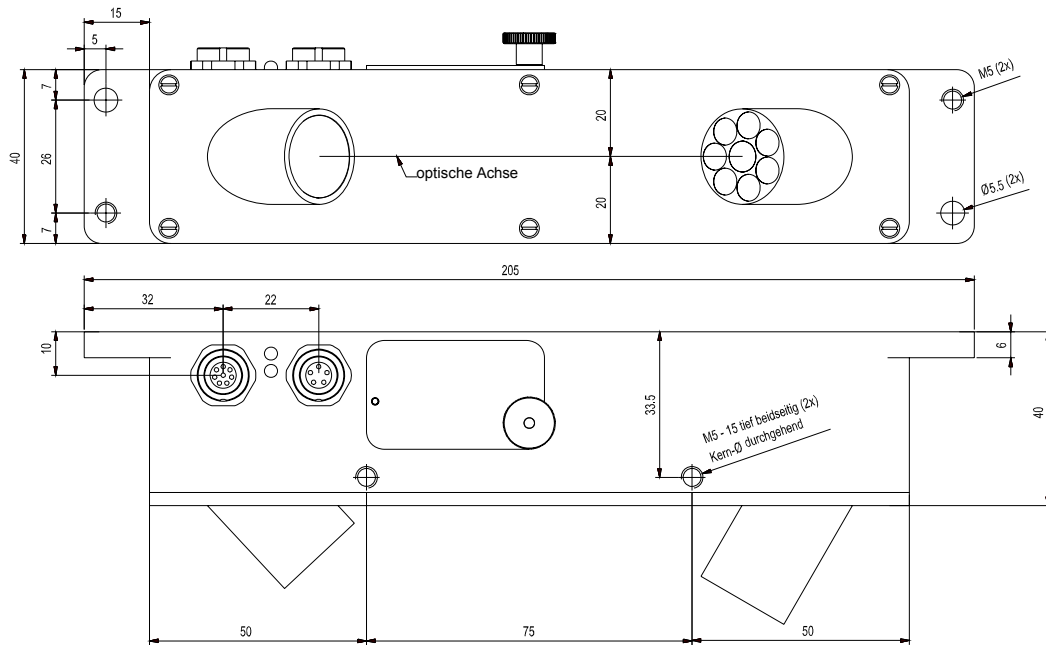

Alle Abmessungen in mm

Working Distance

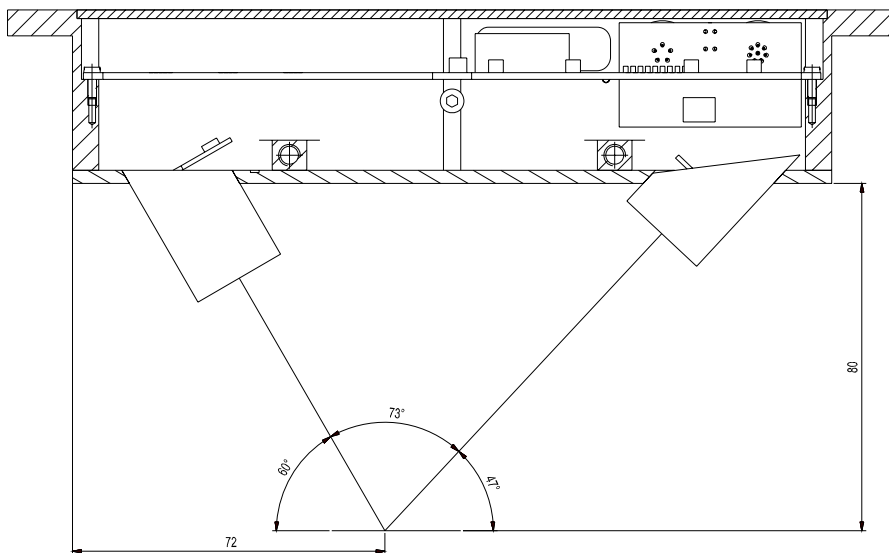

All dimensions in mm



Approach switch INI-18

Model	INI-18
Switching distance	typ. 8.0 mm
Mounting	not flush mounted
Voltage supply	+10 ... +30 VDC
Max. load	200 mA
Max. switching frequency	typ. 500 Hz
Ambient temperature	-25°C ... +70°C
Enclosure rating	IP67
Switching state indication	via LED in the M12-connector
Housing material	Brass, nickel-plated
Type of connector	4-pin M12-connector

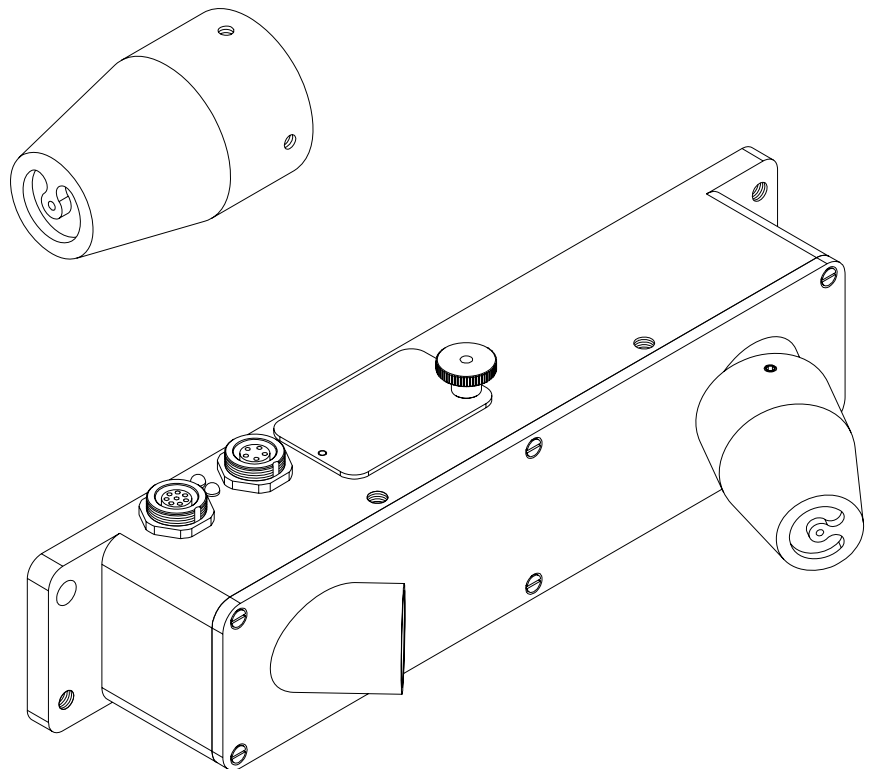
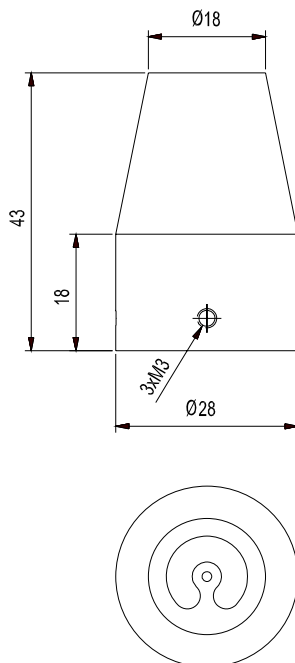

Tube TB-80
 (for transmitter-/receiver optics)

All dimensions in mm

Connector Assignment

**Connection to PLC:
8-pole fem. connector Binder Series 712**

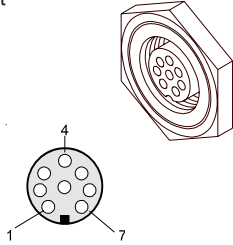
Pin No.	Color	Assignment
1	white	GND (0V)
2	brown	+24VDC
3	green	IN0
4	yellow	IN1
5	grey	OUT0
6	pink	OUT1
7	blue	n.c.
8	red	n.c.



Connecting cable: cab-las8/SPS

**Connection to PC:
5-pole fem. connector Binder Series 702**

Pin No.	Assignment
1	GND (0V)
2	TX0
3	RX0
4	n.c.
5	n.c.

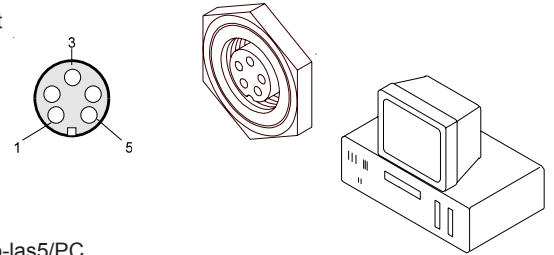

Connecting cable: cab-las5/PC

Connecting Cables

Connecting cables:

cab-las8/SPS	Length: 2 m	Sheath: PUR
cab-las5/PC	Length: 2 m	Sheath: PUR

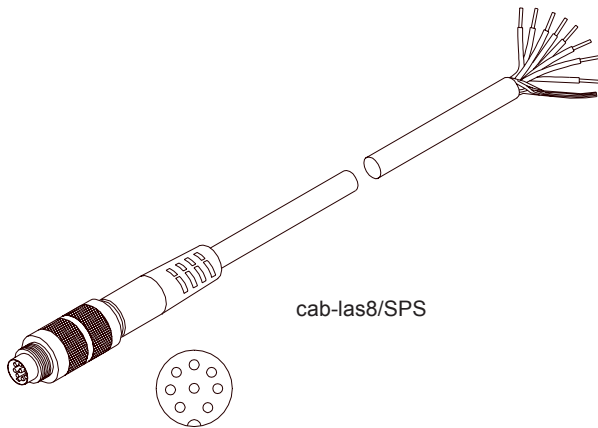

cab-las8/SPS

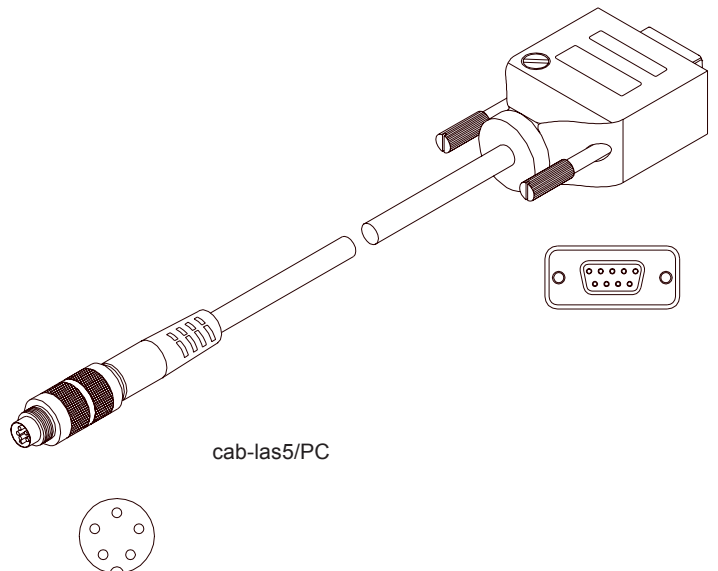

cab-las5/PC

Laser Warning

The laser wire counters of LWC Series comply with laser class 2 according to EN 60825. The use of these laser transmitters therefore requires no additional protective measures.

The laser wire counters of LWC Series are supplied with a laser warning label.

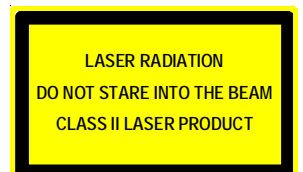



Parameterization

Windows® software SI-LWC-Scope:

The LWC-80 laser wire counter can be easily parameterised with the Windows® user interface. For this purpose the LWC-80 system is connected to the PC with the serial interface cable cab-las5/PC. When parameterisation is finished, the PC can be disconnected again.

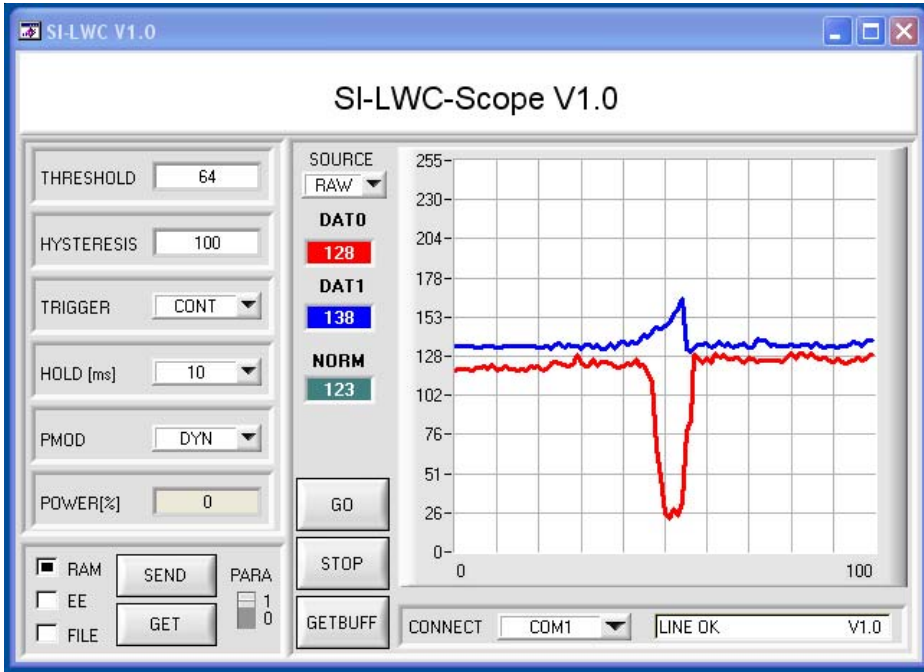

Windows® user interface



PMOD:

In this function field the operating mode of automatic power correction at the transmitter unit (laser) can be set.

FIX: In this operating mode the POWER function field is *enabled* for setting purposes. The laser transmission power is kept constant at the value set in the POWER function field.

DYN: In this operating mode the POWER function field is *disabled* for setting purposes. The laser transmission power is automatically and dynamically controlled in accordance with the amount of radiation that is diffusely reflected from the object. By using the intensities measured at the receiver, the automatic control circuit attempts to adjust the transmission power in such a way that the dynamic range is not exceeded.



POWER[%]:

In this function field the intensity of the laser diode can be set (0% = Laser OFF, 100% = full laser diode intensity).

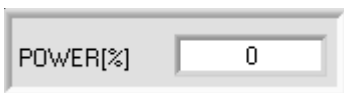

HOLD:

This function field displays the output hold pulse length set with DIP switches DIP2, DIP3, and DIP4.

Please note:

The HOLD function field is *disabled*, i.e. it does not respond to mouse clicks or to the keyboard. However, the object is still used as a self-defined display object, i.e. the value set via the DIP-switch will be displayed when the GET button is pressed.



PARA:

This changeover switch determines whether the parameters BACKLIM, REGCNT, AVERAGE, DEAD TIME MODE, and DEAD TIME are displayed or hidden.

1 = Hide parameters
0 = Display parameters

Parametrisierung

THRESHOLD

HYSTERESIS

THRESHOLD:

Input field for the lower threshold. The sensor sensitivity increases with a higher THRESHOLD value.

HYSTERESIS:

Input field for the desired hysteresis. For detecting an edge, the NORM VALUE of the two RAW SIGNALS must drop below a certain THRESHOLD during measurement to initiate a counting event.

Please note:

The THRESHOLD and HYSTERESIS function fields are disabled, i.e. they do not respond to mouse clicks or to the keyboard. However, the object is still used as a self-defined display object, i.e. the values set via the HEX-switch will be displayed when the GET button is pressed.

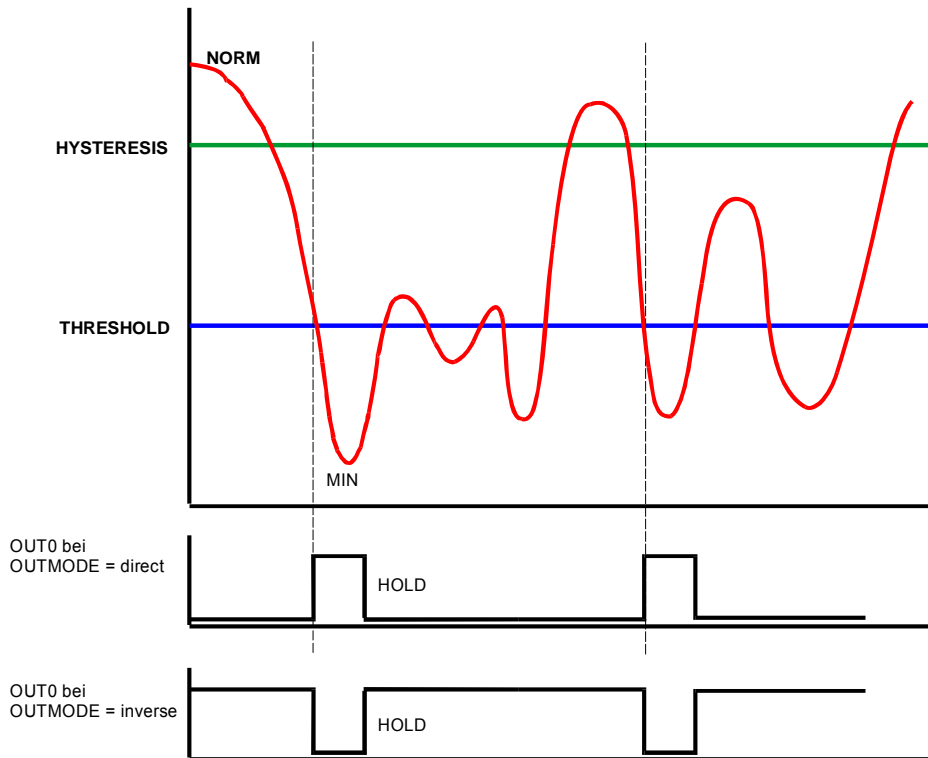

When the sensor detects an edge (NORM VALUE drops below THRESHOLD), a search for the minimum NORM VALUE is performed until the end of the DEAD TIME (TRIGGER=CONT) or the ACTIVE TIME (TRIGGER=EXT) and during HOLD. This minimum value is stored in a 16-value JUMP-BUFFER that can be read out with the GETBUFF software button.

After the value has dropped below a THRESHOLD, the NORM VALUE must again lie above the value set under HYSTERESIS, to allow renewed edge detection. This is an additional safety feature to suppress multiple counting around the THRESHOLD.

Parameterization

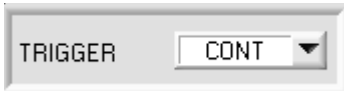

TRIGGER = CONT:

Measurement is performed continuously.

TRIGGER = EXT:

An ACTIVE WINDOW is set for the sensor by the two inputs IN0 and IN1. The window is opened with a positive signal edge at IN0, and is closed again with a positive signal edge at IN1. The sensor measures during its ACTIVE TIME, and if it detects an edge, an output counting pulse is provided immediately after the ACTIVE WINDOW is closed.

Only one edge can be detected during the ACTIVE TIME. Output OUT1 serves for monitoring the active time. For renewed edge detection, the two inputs must detect a negative signal edge.

TRIGGER = ADJ EXT:

For future measurements with an active window (TRIGGER = EXT), this mode makes it easier for the user to adjust the two initiators for the active window; see picture below.

For operating the sensor with an active window, two initiators must inform the sensor about the active time. As described above, the active window is opened with a positive signal edge at input IN0 and is closed again with a positive signal edge at input IN1.

The TRIGGER = ADJ EXT mode was introduced to allow improved sensor adjustment. When this mode is selected, the sensor records the time from one positive signal edge at IN0 to the next positive signal edge at IN0 and evaluates this time as 100%. This is shown in the graphic display, when the GO button is pressed and SOURCE = EXT is selected. When the GO button is pressed, the data are automatically updated after one second. The value of 100 on the x-axis corresponds with 100% (time from IN0 to IN0).

The red graph visualises the length of the active window in percent of the time between IN0 and IN0. The blue graph visualises the appearance of an edge in percent of the time between IN0 and IN0.

It can be seen in the example shown here that the active window is equal to 59% of the time from IN0 to IN0, i.e. the sensor detected a positive signal edge at IN1 after 59% of IN0 to IN0, which closed the active window. The edge was detected at 30% of IN0 to IN0. These two values are also shown in the EDGE [%] and WIN [%] display fields.

In practice, the active window should be open approx. 60% of IN0 to IN0. The edge should lie in the middle of the active window (30%).

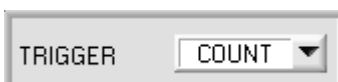

TRIGGER = COUNT

With this evaluation mode it can be preset how many edges between two positive signal edges (e.g. from an angle encoder) must be counted at input IN0 for the sensor to provide an OK signal at OUT1. As usual the output signal upon detection of an edge is provided at OUT0.

Application example:

Objects that are transported by means of mechanical or other kinds of grippers. The trigger signals (+24V) can be supplied to the sensor by means of inductive sensor or light barriers, etc. The advantage of this method of measuring is that the sensor is completely independent of the speed.

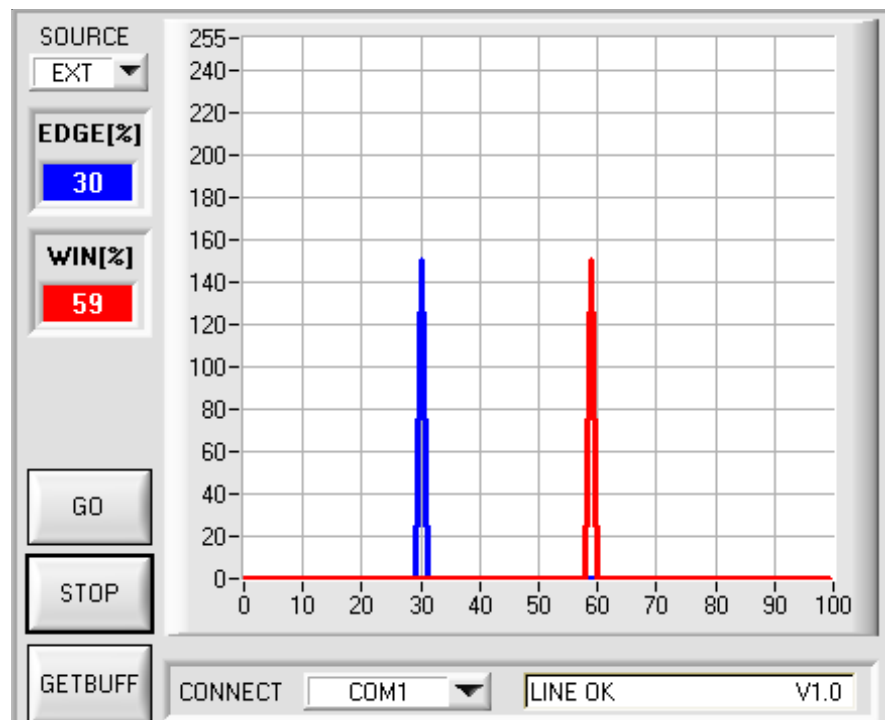
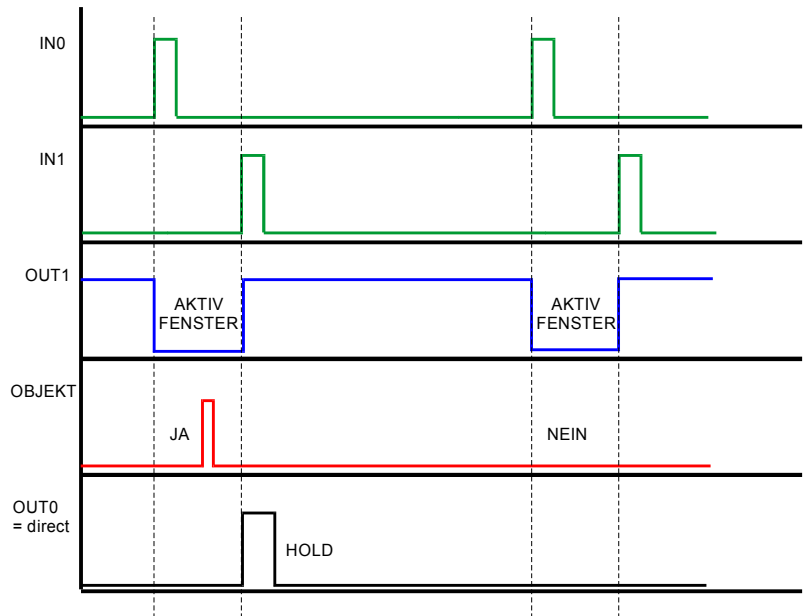



Parameterization

BACKLIM:

In this edit-box an intensity limit can be set. If the intensity that arrives at the receiver unit DAT0 (display window in the user interface) drops below this limit, no evaluation will be performed.

REGCNT:

This edit-box serves for setting after how many loop runs dynamic laser diode correction should be performed.

Example: SCAN frequency 15 kHz is equal to 66.6 μ s
REGCNT = 75

Calculation: 66.6 μ s * 75 = 5 ms

Result: Dynamic correction is performed every 5ms

Explanation:

Flatly rising magazines are detected, because dynamic correction is not performed with every loop run, and the jump is automatically compensated, so to speak.

The EDIT-BOX REGCNT is *enabled* when PMOD = DYN.

When PMOD = FIX the EDIT-BOX REGCNT is *disabled* as no laser transmitting power correction is done.

AVERAGE:

This edit-box serves for setting averaging through NORM.

The minimum value for averaging is 1.

The maximum value for averaging is 128.

An average of 1 is sufficient for most applications.

Please note:

If AVERAGE = 1, the internal scan frequency = 15 kHz.

If AVERAGE = 2, the internal scan frequency = 7.5 kHz.

If AVERAGE = 4, the internal scan frequency = 3.75 kHz.

etc.

OUTMODE:

This edit-box determines how the output impulse should be output at OUT0:

Direct:

When a counting event occurs, output OUT0 changes from LOW (0V) to HIGH (+24V), until HOLD is over.

Inverse:

When a counting event occurs, output OUT0 changes from HIGH (+24V) to LOW (0V), until HOLD is over.

DEAD TIME MODE (DT MODE):

This function field shows the DEAD TIME MODE that is used, and the set dead time.

DT MODE = FIX:

A fixed dead time is used. The dead time is set in milliseconds with DIP switches DIP5, DIP6, DIP7, DIP8.

DT MODE = DYN:

A dynamic dead time is used. The dead time is set in percent with DIP switches DIP5, DIP6, DIP7, DIP8.

The time between two edges is valuated as 100%. The dead time is calculated in accordance with the percent value that is set under DEAD TIME [%]. The dead time can be measured through monitor output OUT1 (low-active).

If TRIGGER = EXT is selected, the sensor operates with an ACTIVE TIME. In this case the input fields DEAD TIME MODE and DEAD TIME [...] are disabled. The active time can be measured through monitor output OUT1 (low-active).

Please note:

These function fields are *disabled*, i.e. they do not respond to mouse clicks or to the keyboard.

However, the object is still used as a self-defined display object, i.e. the value set via the DIP-switch will be displayed when the GET button is pressed.

Parameterization

SOURCE
 RAW
 DAT0
 138
 DAT1
 134
 NORM
 99

GETBUFF

TYPE:

The data that are to be displayed in the graphic window (RAW, NORM) can be selected in this function field.

RAW:

The raw data DAT0 and DAT1 are visualised in the graphic window. In addition these values are displayed in the two numerical value output fields DAT0 and DAT1.

NORM:

The NORM calculated from DAT0 and DAT1 is displayed in the graphic window. In addition this value is displayed in the numerical value output field NORM.

GETBUFF:

When the GETBUFF button is clicked, the last minimum values of the NORM SIGNAL after edge detection are displayed. In addition, the THRESHOLD which the values of the NORM SIGNAL must remain under is visualized in the graphical display window.

Upon detection of an edge the sensor starts to search the minimum value of the NORM SIGNAL during the DEAD TIME and HOLD. This value is then stored in a 16-value ring buffer. Based on these VALUES, the optimum THRESHOLD for the current product run can then be set.

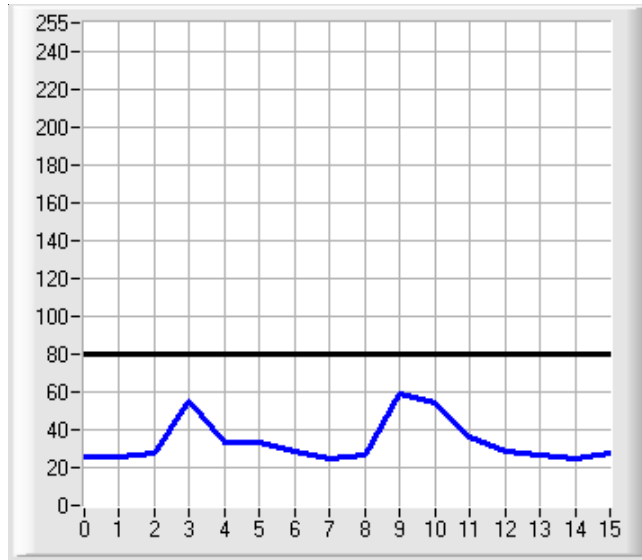

This group of function keys serves for parameter exchange between the PC and the control unit through the serial RS232 interface.

RAM SEND
 EE GET
 FILE

SEND:

When the SEND button is clicked, all the currently set parameters are transferred between the PC and the control unit or to an output file. The target of the respective parameter transfer is determined by the selected button (RAM, EE, or FILE).

GET:

The current setting values can be called up from the control unit by clicking on the GET button. The source of data exchange is determined by the selected button (RAM, EE, or FILE).

RAM:

The current parameters are written to the RAM memory of the control unit, or they are read from the RAM, i.e. these parameters are lost again when the voltage is switched off at the control unit.

EE:

The current parameters are written to the non-volatile memory of the EEPROM in the control unit, or they are read from the EEPROM, i.e. the parameters in the internal EEPROM are stored when the voltage is switched off.

FILE:

A click on this selection button opens an info field with the file name of the current parameter file.

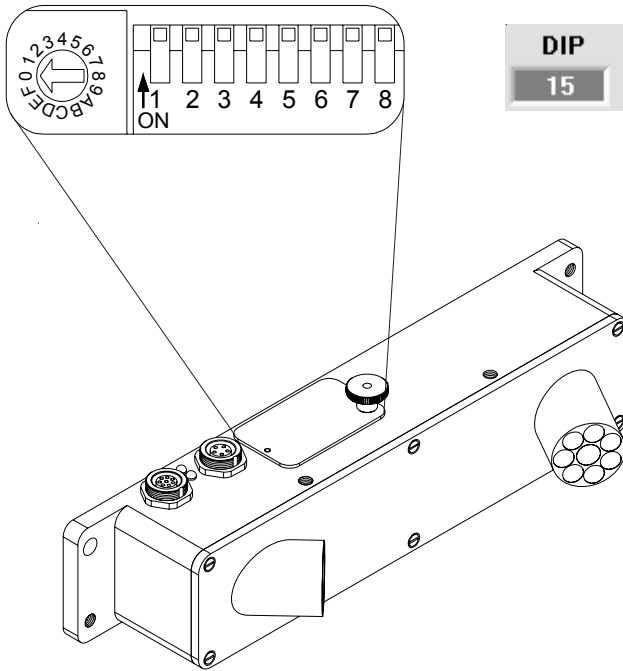

Setting
**Adjustment of DIP switch**

(effective only when TRIGGER = COUNT is activated !)

The setpoint edge number is set with the DIP switches (DIP1 ... DIP8) that are integrated in the sensor. Setting is done in binary form from 0 ... 255.

In addition the setting of the setpoint edge number can be checked with the DIP display window (in this example: 15) after pressing of the GET button.

Adjustment of HEX coding switch

The THRESHOLD value is preset with the hexadecimal switch (HEX) using the following encoding:

Switch position:	Threshold in digits:	Hysteresis in digits:
0	8	100
1	16	100
2	24	100
3	32	100
4	40	100
5	48	100
6	56	100
7	64	100
8	72	100
9	80 (*)	100
A	88	100
B	96	106
C	104	114
D	112	122
E	120	130
F	128	138

**Application Examples****Detection of wires in the production of power cables**

In the production of power cables, individual wires might tear during the winding process, which would impair the quality of the power cables.

An LWC-80 laser sensor reliably detects the individual wires during rotation. Due to the special, intensity- independent evaluation according to the shadowing principle, the wires can be safely detected irrespective of color, surface, and speed of rotation. Automatic dead-time determination prevents multiple pulses per wire.

